

# Mooney™ Flowgrid™ Valve

## 3" Single Port

FLanged CL 150-600 | Buttweld

The 3" Flowgrid Valve is an economical and easy to maintain pilot operated valve for both gas and liquid applications. The valve is designed to be used in conjunction with a self contained pilot control system. The low profile and easy in line maintenance make it ideal for skid mounted, vault, and enclosure installations.

### Specifications

Size	3"
Body Style	Single Port (3")
End Connections	3" CL 150, 300, 600 Flanged and Buttweld
Temperature	Working -20°F to 150°F Emergency -40°F to 175°F
Max. Operating Differential	800 psi
Max. Emergency Differential	1000 psi
Min. Differential	Refer to graph on page 2
Cracking Differential	Refer to graph on page 2
Max. Inlet Pressure	1480 psig <sup>1</sup>
Outlet Pressure Range	Limited By Pilot
Flow Direction	Bi-Directional <sup>2</sup>
Body Taps	Two 1/4" - 18NPT

1. Limited by pilot or flange rating.

2. Reverse flow by changing pilot connections and reversing spring case.

### Materials of Construction

Body and Spring Case	ASTM A 216 GR WCB   Carbon Steel
Throttle Plate	7 - 4PH Stainless Steel or A515 Carbon Steel with ENC Coating
Diaphragm	Nitrile/Nylon <sup>1</sup>
O-Ring and Seals	Nitrile, Optional (Viton)
Bolting	ASTM A 193 GR B7 or Equal
Spring	301 Stainless Steel

1. Refer to diaphragm selection chart on page 2.

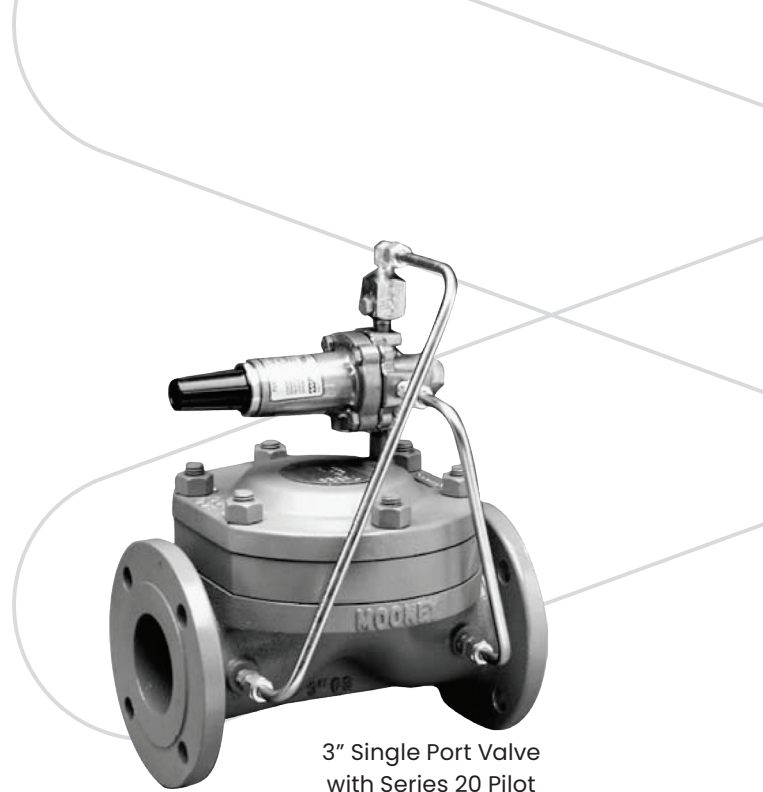

3" Single Port Valve  
with Series 20 Pilot

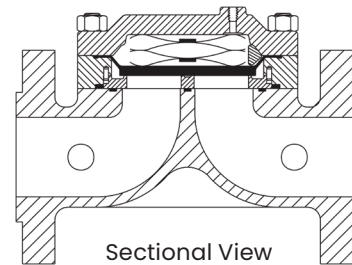

### Overpressure Protection

The Flowgrid Valve is bi-directional and has a full ASME rating on both the inlet and outlet. Overpressure protection is required only if the pressure can exceed the flange or body rating.

The pilots, like most regulators, may have an outlet pressure rating lower than the inlet pressure rating. If this is the case, then some external form of overpressure protection must be provided for the pilot.

Anytime the Flowgrid valve or pilot system is exposed to pressure in excess of its rating, it should be inspected for damage.

### Stock Numbers

3" Single Port Valve	Stock Number	Weight
150# Flanged	FG-16	73 lbs.
300# Flanged	FG-17	85 lbs.
600# Flanged	FG-18	94 lbs.
50-300# Buttweld	FG-61	65 lbs.
600# Buttweld	FG-62	69 lbs.

**Mooney**  
a Baker Hughes business

## Dimensions

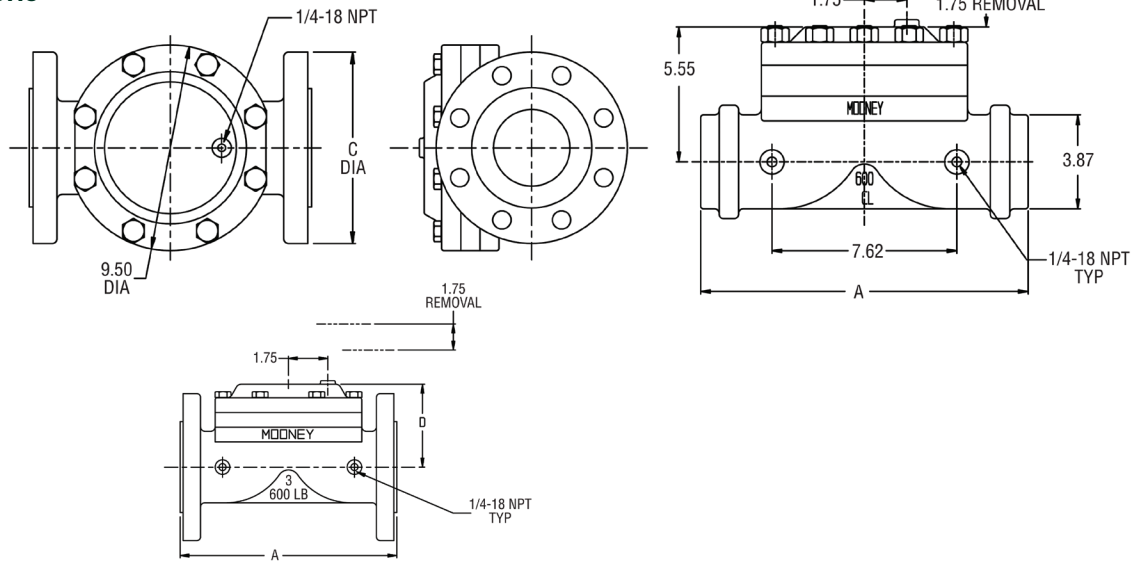

## Minimum Pressure Differential vs. Capacity

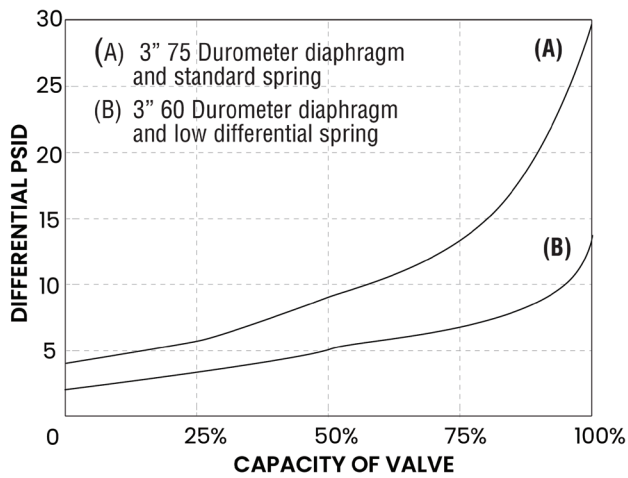

## Flange Dimensions

End Connection	A	B	C	D
150# Flange	11.75	9.00	7.50	5.40
300# Flange	12.50	9.50	8.25	5.40
600# Flange	13.25	6.50	8.25	5.60
Buttweld	13.25		STD ANSI	

## Flow Coefficients and Constants

3" Single Port Valve				Swage Factor	
% Capacity	C <sub>v</sub>	C <sub>1</sub>	C <sub>g</sub>	1.5:1	2:1
100%	96	36	3450	0.98	0.95
75%	81	34	2730	1.00	1.00
50%	68	32	2150	1.00	1.00
35%	49	31	1530	1.00	1.00

Note: Allow a 5% factor of safety when calculating relief capacity.

## Diaphragm Selection

Compound	Temp. Range (°F)	Maximum Differential	Characteristics	Recommended Applications
75 Duro	-20 to 150	1000 psid	Best All Around Material	60 psid to Max. Differential
60 Duro	-25 to 150	300 psid	Best Shutoff at Low Differential Pressure	Low Differential (100 psid or less) or Low Temperature
80 Duro High ACN	-5 to 175	1000 psid	Higher Abrasion and Swelling Resistance	High Differential (400 psid or higher) or Abrasive Conditions with Distillates
80 Duro Low ACN	-20 to 150	1000 psid	Higher Abrasion Resistance and Low Temperature Flexibility	High Differential (400 psid or higher) or Abrasive Conditions at Low Temperatures