

Mooney™ Series 20L Flowgrid™ Pilots

The Series 20L Flowgrid Pilot is a pressure control regulator designed primarily for use as a control pilot for pressure reducing (PRV) and differential pressure (DPV) applications. The Series 20L Pilot is designed for both liquid and gas applications. The pilot is available in both bronze (Series 20L-B) and aluminum (Series 20L-A).

Specifications

Body Materials	Series 20L Bronze	Series 20L Aluminum
Body Style	Pressure Reducing Valve (PRV)	Pressure Reducing Valve (PRV)
Orifice Size	0.15 Inches (Standard) 0.17 Inches (Optional)	0.15 Inches (Standard) 0.17 Inches (Optional)
Connections	1/4" NPT inlet, outlet & loading 1/92" NPT Sense	1/4" NPT inlet, outlet & loading 1/2" NPT Sense
Temperature Nitrile Diaphragm & O-rings	Working -20°F to 150°F Emergency -40°F to 200°F	Working -20°F to 150°F Emergency -40°F to 200°F
Maximum Static Inlet Pressure	1500 psig	750 psig
Maximum Static Loading Pressure ¹	1500 psig	750 psig
Maximum Operating Inlet Pressure	750 psig	750 psig
Maximum Operating Loading Pressure	750 psig	750 psig
Outlet Pressure	750 psig	750 psig
Maximum Sensing Pressure	300 psig	150 psig
Maximum Spring Housing Pressure	300 psig	150 psig
Set Pressure Range Spring Ranges	5 Inches W.C. to 8 psig (Five springs - Refer to page 2 for each spring range)	

1. Anytime the Flowgrid Pilot or Valve is exposed to pressures in excess of its rating it should be inspected for damage.

Flow Coefficients and Constants

Series 20/20S/20H/20HS Pilots			
	C_v	MAX C_g	MAX C_v
0.15 Orifice (standard)	38	9.58	0.25
0.17 Orifice (optional)	38	11.18	0.29

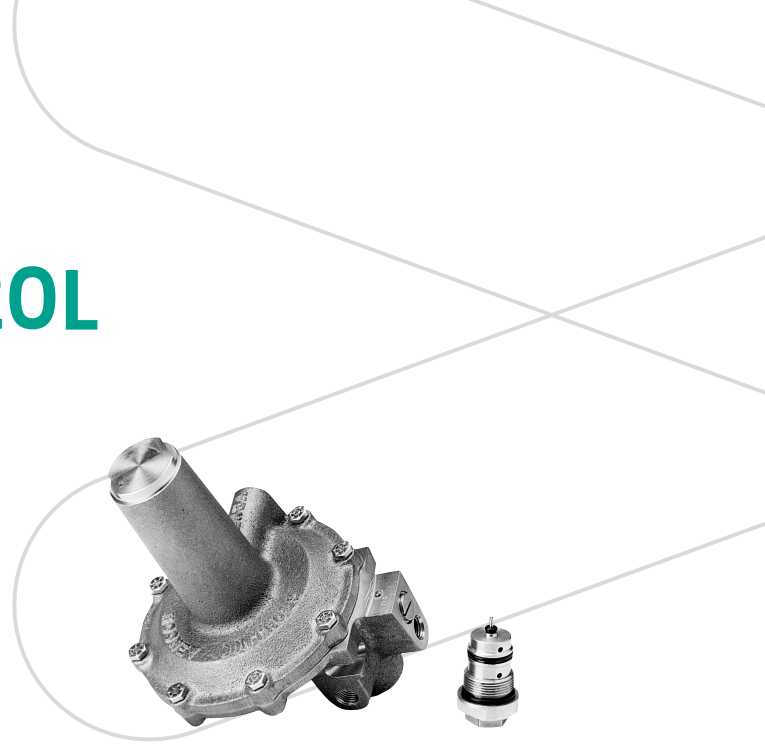

Series 20L Flowgrid Pilot with Body Insert (Cartridge) Removed

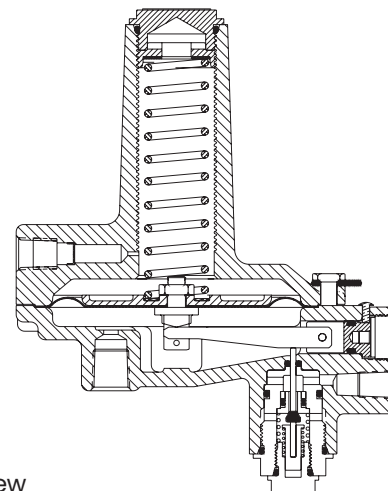

Sectional View

Materials of Construction

Body & Spring Housing	Cast Manganese Bronze or Cast A356-T6 Aluminum
Body Insert & Closing Cap	Brass or 6061 T-6 Aluminum
Orifice	304 Stainless Steel or Delrin
Plug & Stem	Nitrile/304 Stainless Steel Viton/304 Stainless Steel
Lever	Zinc Plated Carbon Steel
Pivot	Brass or Aluminum (Anodized)
Vent Orifice	304 Stainless Steel
Diaphragm	Nitrile/Nylon
O-rings	Nitrile or Viton

Dimensions

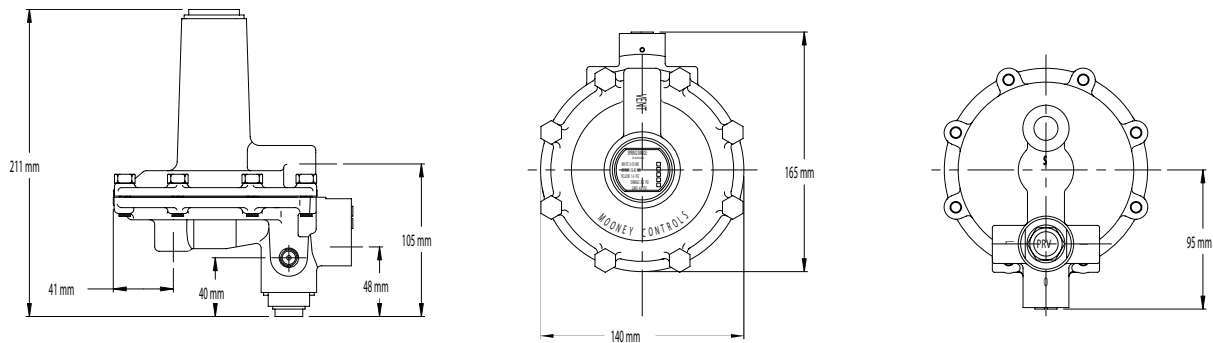

Pilot Performance

Series 20L Pilot		Pressure Reducing Mode Restrictor Set at 4		
Spring Range	Color	Lock-up (psi)	Droop (psi) @ Max. Capacity ¹	Boost @ Constant Flow (psi) ²
5 - 15 inches W.C.	White	1.0 inches W.C.	0.5 inches W.C.	0.7 inches W.C.
10 - 40 inches W.C.	Brown	2.0 inches W.C.	2.0 inches W.C.	0.7 inches W.C.
1 - 3 psi	Yellow	0.2 psig	0.15 psig	0.025 psig
2 - 5 psi	Orange	0.35 psig	0.25 psig	0.025 psig
4 - 8 psi	Gray	0.5 psig	0.30 psig	0.025 psig

1. Constant Inlet Pressure (P_i).

2. Per 100 psi decrease in inlet pressure (P_i).

Trim Options

All Series 20L Pilots		
Internal Trim	Std. Construction	Option
Orifice	304 SST (0.15 Standard Orifice)	304 SST (0.17 Orifice)
Plug/Stem	Nitrile/304 SST	Viton/304 SST
Diaphragm	Nitrile/Nylon	Nitrile/Nylon
O-ring	Nitrile	Viton

Series 20L Pilot (Aluminum)	Spring Color	PRV Stock	Weight
5 - 15 inches W.C.	White	FP-105	4 lbs
10 - 40 inches W.C.	Brown	FP-106	4 lbs
1 - 3 psi	Yellow	FP-107	4 lbs
2 - 5 psi	Orange	FP-108	4 lbs
4 - 8 psi	Gray	FP-109	4 lbs

Stock Numbers

Series 20L Pilot (Bronze)	Spring Color	PRV Stock	Weight
5 - 15 inches W.C.	White	FP-100	9 lbs
10 - 40 inches W.C.	Brown	FP-101	9 lbs
1 - 3 psi	Yellow	FP-102	9 lbs
2 - 5 psi	Orange	FP-103	9 lbs
4 - 8 psi	Gray	FP-104	9 lbs

Cartridge Sectional View

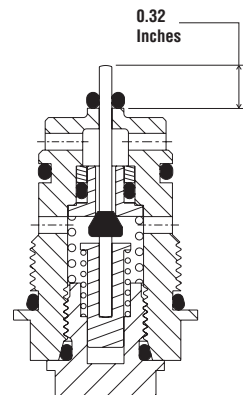

PRV Mode

Note: The Series 20L may not be used in the Back Pressure BPV/Relief) Mode to control the Flowgrid Valve because the Series 20L Pilot set point range is below the minimum differential required to open the Flowgrid Valve.

Sense point recommendations: Sense point should be at least 8-10 pipe diameters away from the regulator and away from turbulence causing objects such as valves, tees, elbows, and reducers. Pipeline gas velocity at the sense point should be less than 100 ft/sec (30 m/s).

Copyright 2020 Baker Hughes Company. All rights reserved. Baker Hughes provides this information on an "as is" basis for general information purposes. Baker Hughes does not make any representation as to the accuracy or completeness of the information and makes no warranties of any kind, specific, implied or oral, to the fullest extent permissible by law, including those of merchantability and fitness for a particular purpose or use. Baker Hughes hereby disclaims any and all liability for any direct, indirect, consequential or special damages, claims for lost profits, or third party claims arising from the use of the information, whether a claim is asserted in contract, tort, or otherwise. Baker Hughes reserves the right to make changes in specifications and features shown herein, or discontinue the product described at any time without notice or obligation. Contact your Baker Hughes representative for the most current information. The Baker Hughes logo, Flowgrid and Mooney are trademarks of Baker Hughes Company. Other company names and product names used in this document are the registered trademarks or trademarks of their respective owners.

Baker Hughes 

valves.bakerhughes.com