

P203 Pressure Reducing Regulator

The P203 and P203H are available with a true monitor regulator, which acts independently of the main regulator. The monitor provides equivalent overpressure protection when compared to a standard two-regulator monitor setup. If one regulator fails, the other regulator provides control and overpressure protection.

Applications

- Commercial / Industrial / Service
- Gas Engine Control
- Gate Applications

Features

- Integral Monitoring
- Fast Acting Minimizing Shock
- Internal Relief

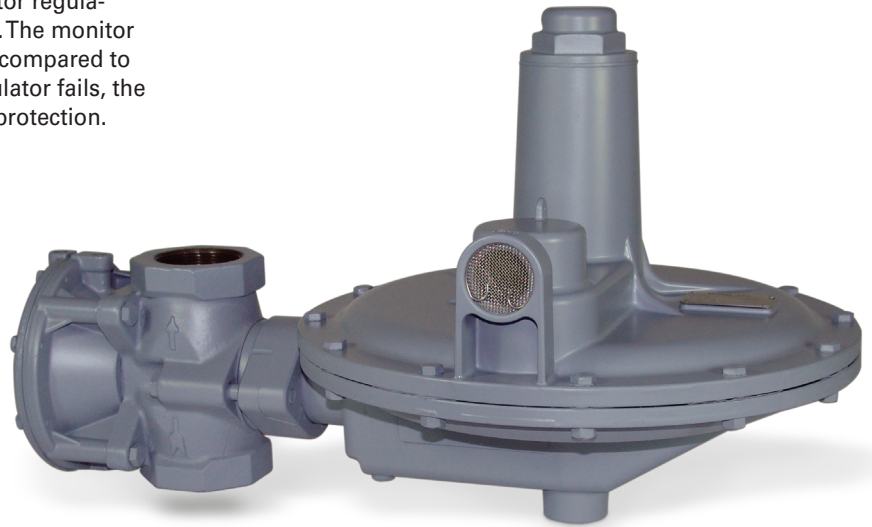

Materials of Construction

Adjusting Screw	Aluminum
Body	Ductile Cast Iron
Bonnet	Aluminum
Closing Cap	Aluminum
Diaphragm	Nitrile
Lower Casing	Aluminum
Molded Seat Assembly	Nitrile
Orifice	Aluminum

Specifications

Maximum Inlet	See Table 1	
Maximum Emergency Outlet	15 PSIG	
Port Sizes	1.5 NPT	
	1.5 NPT x 2 NPT	
	2 NPT	
Orifice Sizes	1/4"	
	3/8"	
	1/2"	
	3/4"	
	1"	
	1-3/16"	
End Connections	NPT	
	125 FF Flange	2" Iron Units Only
Temperature Range	-20°F to 180°F	
	-29°C to 82°C	

P203 Max Inlet Pressures

Orifice Inches	Range	Maximum Inlet Pressure	
		PSIG	BAR
1/4"	Any	125	8.618
3/8"	Any	125	8.618
1/2"	Any	100	6.894
3/4"	Any	60	4.136
1"	0-5" WC thru 0.5-1.0 PSIG	25	1.723
	1-1.6 thru 1.25-3.25 PSIG	30	2.068
1-3/16"	0-5" WC thru 0.5-1.0 PSIG	13	0.896
	1-1.6 thru 1.25-3.25 PSIG	14	0.965

Type	Control Spring Part Number and Color	Maximum Downstream Pressure with Integral Monitor in Operation		Maximum Flow Through Internal Relief Valve with Integral Monitor in Operation ¹		Monitor Spring Number & Color	Outlet Pressure Range		Number of Lower Spring Seats
		PSIG	mBAR	SCFH	Nm ³ /h		WC or PSIG	mBAR	
P203	655-697-002, Brown	0.8	60	950	25.5	655-746-000, Green	0-5" WC	0-12	0
	655-697-003, Red	0.8	60	1000	26.8		4-9.5" WC	10-24	1
	655-697-004, Black						8-14" WC	20-35	2
	655-697-005, White	1.4	100	1200	32.2	655-746-001, Red	8-12" WC	20-30	0
		1.4	100	1350	36.2		10-20" WC	25-50	1
		1.8	120	1600	42.9	655-746-002, Blue	11-21" WC	27-52	0
		2.2	150	1800	48.2	655-746-001, Red	14-28" WC	35-70	2
	655-697-006, Dark Green	2.8	190	1900	50.9	655-746-002, Blue	18-33" WC	45-82	1
		3.0	210	2000	53.6	655-746-003, Silver	0.5-1.0 PSIG	34-69	0
	P203H	655-697-007, Dark Blue	3.0	210	2200	60.0	655-746-002, Blue	1.0-1.6 PSIG	69-110
3.8			260	2200	60.0	655-746-003, Silver	0.75-1.6 PSIG	52-110	1
655-697-008, Orange		4.0	280	2500	67.0	655-746-003, Silver	1.25-2.25 PSIG	86-155	2
		5.0	350	3000	80.4	655-746-003, Silver	1.25-3.25 PSIG	86-224	3
655-697-008, Orange		6.0	410	3000	80.4				

1. Flow of 0.6 specific gravity natural gas in SCFH at 60°F and 14.7 PSIA and Nm³/h at 0°C and 1.01325 BAR.

How Does the P203 Series Work?

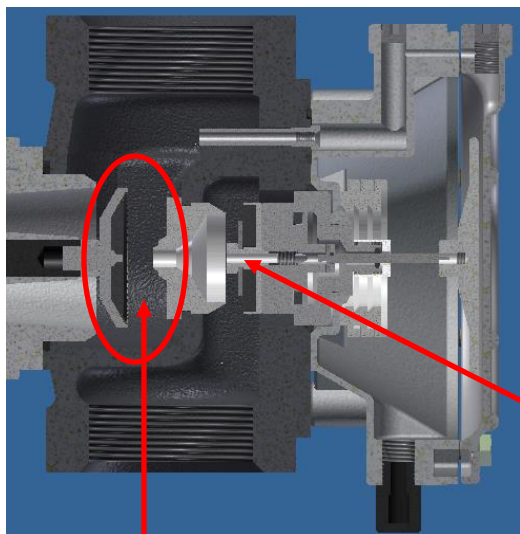

Under normal operational conditions, the P203 Series performs as the P200. When there is a demand downstream of the regulator, the main valve disk moves away from the orifice to allow flow. The Monitor diaphragm and piston are always in motion based on outlet feedback through the pitot tube at the outlet.

Secondary or monitor orifice & valve disk

Main orifice & valve disk

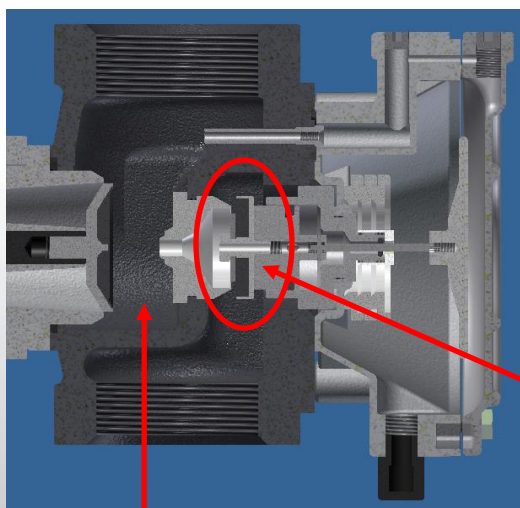

The monitor module will activate when the system experiences a failure such as the main valve disk is stuck open or the lever disengages from the valve stem assembly. When the P203 main regulator fails to regulate and the output pressure climbs, the increased output pressure will move the monitor valve disk towards the secondary sealing surface of the orifice.

Monitor valve disk starts to regulate

Main seat lodged open

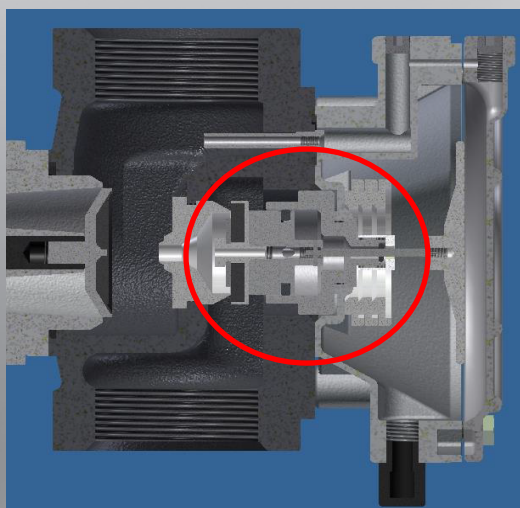

Once the output pressure has increased 7" to 28" WC above the set operating output pressure, the monitor valve disk will fully seal on the secondary sealing surface of the orifice. At this point, the only supply pressure that is passing through the unit is passing through the tiny bleed hole on the disk holder screw and venting directly out the main regulator diaphragm assembly and through the main regulator's vent assembly.

BelGAS P203 Part Number Selection

Before attempting to select a BelGAS P203, several pieces of information should be known: port size, the supply pressure the unit operates at normally, the output pressure the unit operates at normally, the downstream flow requirement during normal operation, the maximum amount of output pressure the unit is allowed to have during an over pressurization situation, and the media the unit will be regulating.

Example #1

Known Requirements

1.5 NPT
60 PSIG inlet
9" WC outlet under normal conditions
18,000 SCFH air
Should not rise above 1.3 PSIG

Port Size

The code of for 1.5 NPT in the Port Size section is 14.
P203X14XX0XXXXX

Outlet Pressure Range

It's best to operate in the middle of the range in order to preserve the life of the unit's springs. Since the output pressure is supposed to be a 9" WC during normal operation, the unit could be either the G2 or R0 option from the Monitor Range section. G2 has a range of 8-14" WC and R0 has a range of 8-12" WC. That means the code for the Spring Coordination section is 18 and the code for the Version section is 0.

P203014180XXXG2 or P203014180XXXR0

Downstream Flow Requirements

The unit needs to flow at least 18,000 SCFH under normal operation. According to P200 Series flow tables for that spring range and outlet pressure droop, both the 1/2" orifice and the 3/4" orifice generated more than 18,000 SCFH. The 1/2" orifice generates 19,300 SCFH flow of air. The 3/4" orifice generates 20,000 SCFH flow of air.

P2030141808XXG2 or P2030141808XXR0
or P203014180BXXG2 or P203014180BXXR0

Body and Bonnet Orientation

BelGAS offers sixteen different body/bonnet orientation combination controlled through two digits in the part number.

If no special orientation is required the 1D orientation is selected.

P20301418081DG2 or P20301418081DR0 or P203014180B-1DG2 or P203014180B1DR0

Over Pressurization Conditions

Since the unit cannot climb above 1.3 PSIG, the R0 option for Monitor Range section is eliminated. The R0 option for the Monitor Range can climb to 1.4 PSIG per the table of the catalog.

P20301418081DG2 or P203014180B1DG2

Based on the criteria provided, both regulators listed above can handle the application. However, the 3/4" orifice will flow more than the 1/2" orifice. So if more flow rate is desir-

able in this particular function: P203014180B1DG2

Example #2

Known Requirements

2" 125 FF
40 PSIG inlet
2.4 PSIG outlet under normal conditions
12,000 SCFH air
Rotometer present downstream of the regulator

Port Size

The code for 2" 125FF in the Port Size section is 16. In the Special Construction section, you should put code E.
P203X16XXEXXXXX

Version

Since there is a rotometer downstream of the regulator. the code for the Version selection should be an S. This allows for the installation of a throat stabilizer in the neck of the regulator. The stabilizer will allow the unit to function with minimal amount of cavitation.

P203S16XXEXXXXX

Outlet Pressure Range

It's best to operated in the middle of the range in order to preserve the life of the unit's springs. Since the output pressure is supposed to be at 2.4 PSIG during normal operation, the unit should be the S3 option from the Monitor Range section. S3 has a range of 1.25 - 3.25 PSIG. That means the code for the Spring Coordination section is 03.

P203S1603EXXXX3

Downstream Flow Requirements

The unit needs to flow at least 12,000 SCFH under normal operation. According to the P200 Series flow tables for that spring range and outlet pressure droop, the 3/4" orific can generate more than 12,000 SCFH. The 3/4" orifice generates 13,800 SCFH flow of air.

P203S1603EBXXS3

Body and Bonnet Orientation

BelGAS offers sixteen different body/bonnet orientation combination controlled through two digits in the part number. If no special orientation is required, the 1D orientaten is selected.

P203S1603EB4FS3

P203 Dimensions

Body Size	A		B	C	D	
	Inches	NPT			NPT	125 FF Flange
1.5	6.13		11.03	18.09	4.18	
1.5 x 2	6.13		11.03	18.09	4.18	
2	6.13	10	10.59	17.66	4.61	4.61

P203 Regulator Rebuild Kits

	Kit Includes	Part Number
P203	Main Regulator - Diaphragm, disk holder assembly, cap gasket and body/lower casing O-ring. Monitor - disk holder assembly, diaphragm, pilot tube O-ring, piston guide O-rings, piston ring, and piston assembly O-ring	971-203-000

P203 Stabilizer Kit

	Kit Includes	Part Number
P203, P203H, and P203S	Stabilizer kit for downstream dampening	971-200-004

P203 Conversions Kits

	Kit Includes	Part Number
P203 and P203S	Brown main spring, green monitor spring, no spring seats	971-203-0G0
	Red main spring, green monitor spring, one spring seat	971-203-6G1
	Black main spring, green monitor spring, one spring seat	971-203-9G1
	White main spring, green monitor spring, two spring seats	971-203-0G2
	White main spring, red monitor spring, no spring seats	971-203-0R0
	White main spring, red monitor spring, one spring seat	971-203-0R1
	White main spring, blue monitor spring, no spring seats	971-203-0B0
	Green main spring, red monitor spring, two spring seats	971-203-0R2
	Green main spring, blue monitor spring, one spring seat	971-203-0B1
P203H and P203S	Green main spring, silver monitor spring, no spring seats	971-203-0S0
	Blue main spring, blue monitor spring, two spring seats	971-203-0B2
	Blue main spring, silver monitor spring, one spring seat	971-203-0S1
	Orange main spring, silver monitor spring, two spring seats	971-203-0S2
	Orange main spring, silver monitor spring, three spring seats	971-203-0S3

P203 2" NPT 125FF

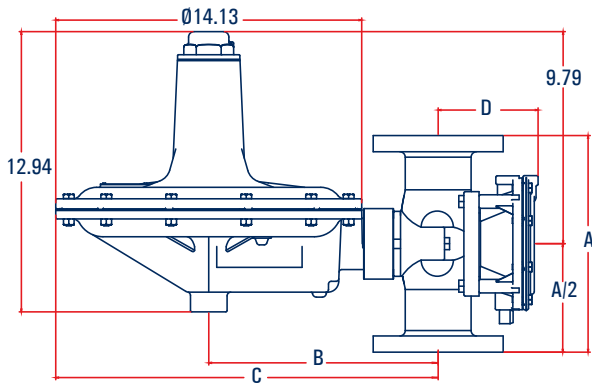

P203 2" NPT

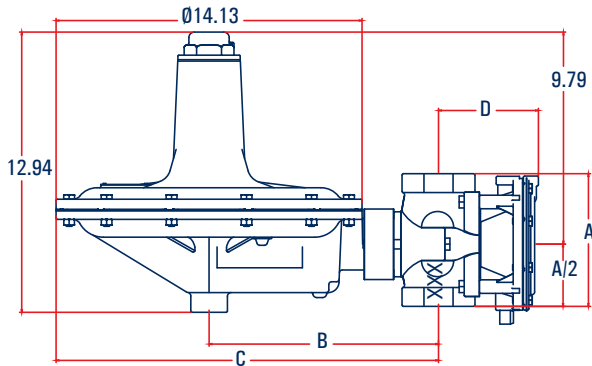

P203 1-1/2" NPT

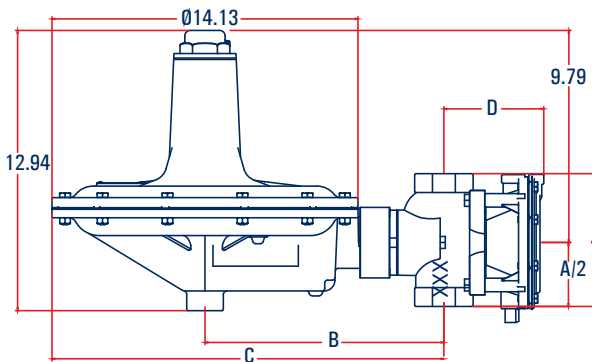

P203 Part Matrix

P203									
									Version
O									Normal
H									High Pressure
P									External Pressure Registration
S									Throat Stabilizer
									Port Size
14									1.5 NPT
15									1.5 x 2 NPT
16									2 NPT
									Spring Range
04									use with G0 Monitor
06									use with G1 Monitor
09									use with G1 Monitor
18									use with G2, R0, R1, B0 Monitor
30									use with R2, B1, S0 Monitor
02									use with B2, S1 Monitor
03									use with S2, S3 Monitor
									Special Construction
0									MPT
									Orifice
4									1/4"
6									3/8"
8									1/2"
B									3/4"
D									1"
F									1-3/16"
									Port Orientation
1									Up (Standard)
2									Down
3									Right
4									Left
									Bonnet Vent Orientation
C									12 O'Clock
D									3 O'Clock (Standard)
E									6 O'Clock
F									9 O'Clock
									Monitor Ranges
									WC or PSIG BAR
G0									0-5" WC 0 - 11.20 use with 04 Main Spring
G1									4 - 9.5" WC 9.96 - 23.66 use with 06 or 09 Main Spring
G2									8-14" WC 19.92 - 34.87 use with 18 Main Spring
R0									8-12" WC 19.92 - 29.89 use with 18 Main Spring
R1									10 - 20" WC 24.90 - 49.81 use with 18 Main Spring
R2									14 - 28" WC 54.87 - 69.74 use with 30 Main Spring
B0									11 - 21" WC 27.39 - 52.30 use with 18 Main Spring
B1									18 - 33" WC 44.83 - 82.19 use with 30 Main Spring
S0									0.5 - 1 PSIG 34.47 - 68.94 use with 30 Main Spring
B2									1.0 - 1.6 PSIG 68.94 - 110.31 use with 02 Main Spring
S1									0.75 - 1.6 PSIG 51.71 - 110.31 use with 02 Main Spring
S2									1.25 - 2.25 PSIG 86.18 - 155.13 use with 03 Main Spring
S3									1.25 - 3.25 PSIG 86.18 - 224.07 use with 03 Main Spring

Note: Monitor Range should be chosen prior to choosing Main Spring

Note: Monitor Range should be chosen prior to choosing Main Spring

P203 Normal (0) Relief Capacities

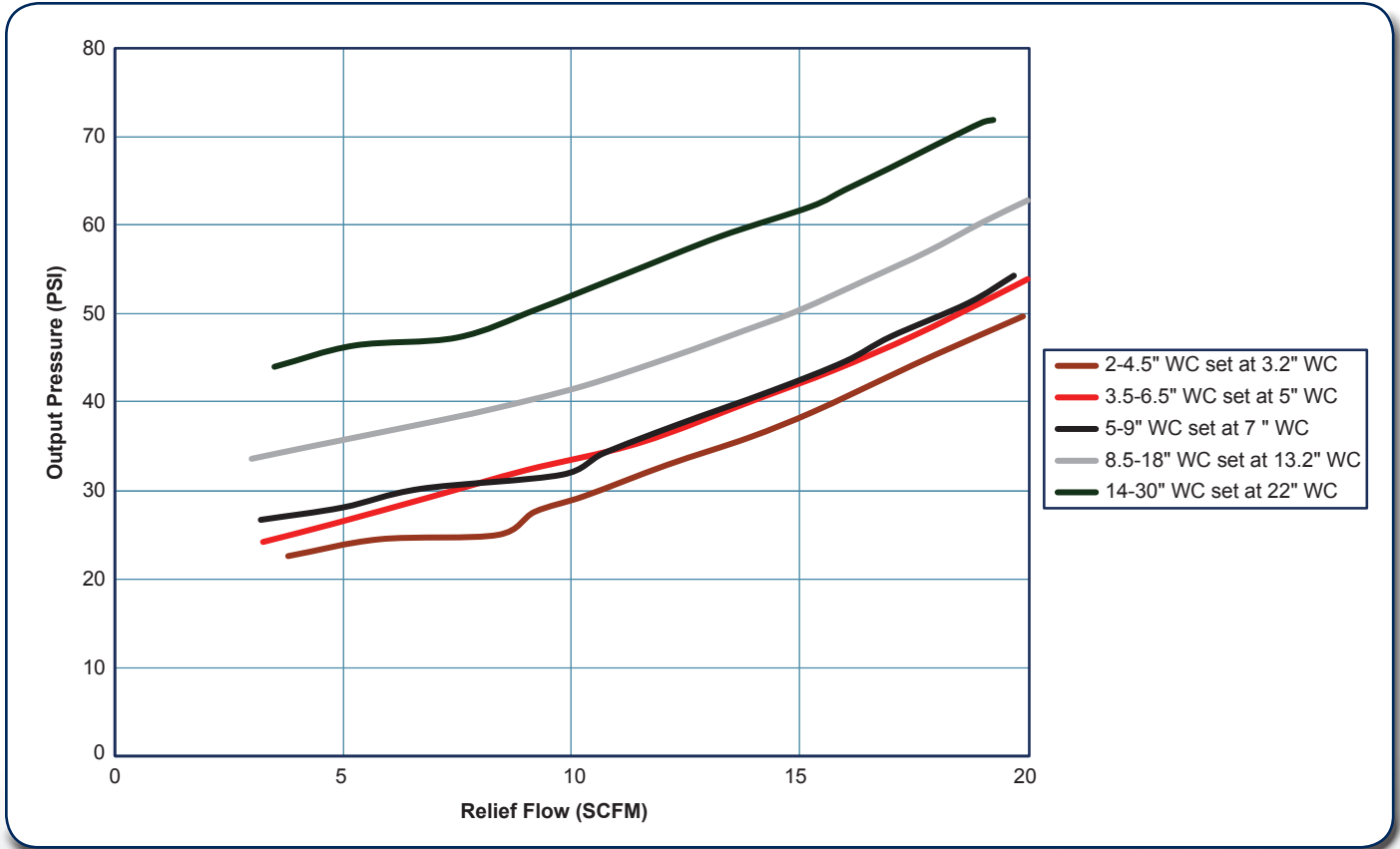

P203 High (H) Relief Capacities

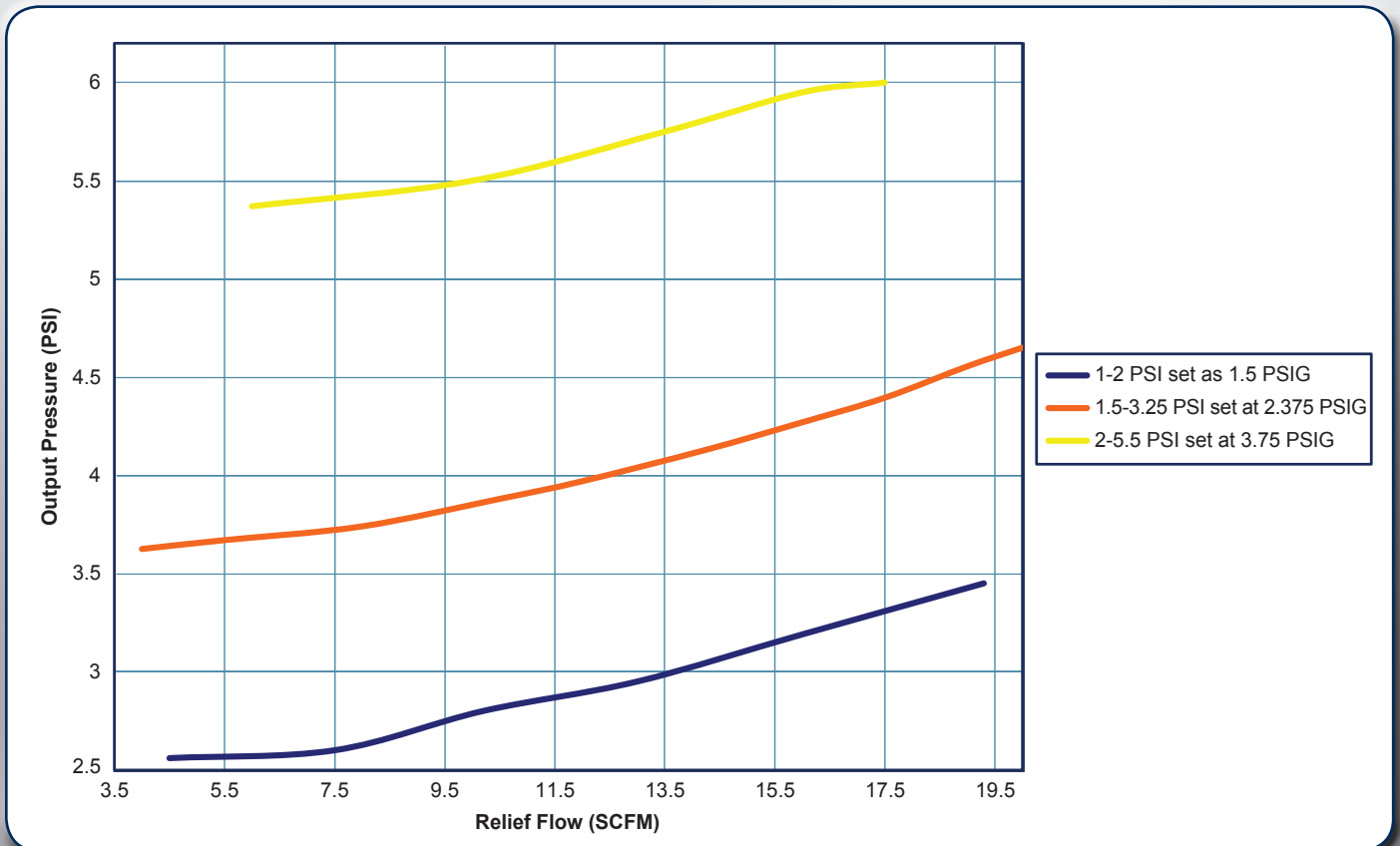

P203 Flow Capacities in SCFH (Nm³/h) of 0.6 Specific Gravity Natural Gas

Outlet Pressure, Spring Part Number, and Accuracy	Inlet Pressure		NPT 1-1/2 Body Size					
			Orifice Size, Inches (mm)					
	PSIG	BAR	1/4 (6.4)	3/8 (9.5)	1/2 (13)	3/4 (19)	1 (25)	1-3/16 (30)
4 inches w.c. (10 mbar) 655-697-002 or 655-697-003 1 inch w.c. (2 mbar) droop 2 inches w.c. (5 mbar) boost	0.4	0.028				1000 (26.8)	1400 (37.5)	1600 (42.8)
	0.5	0.034				1400 (37.5)	1600 (42.8)	1800 (48.2)
	1	0.07	400 (10.7)	800 (21.4)	1200 (32.2)	2100 (56.3)	2500 (67.0)	2700 (72.4)
	1.5	0.10	500 (13.4)	1050 (28.1)	1600 (42.9)	2500 (67.0)	3000 (80.4)	3200 (85.8)
	2	0.14	600 (16.1)	1300 (34.8)	2100 (56.3)	2800 (75.0)	3500 (93.8)	3800 (102)
	5	0.34	1150 (30.8)	2200 (58.9)	3300 (88.4)	4500 (121)	5300 (142)	6000 (161)
	13	0.90	1600 (42.8)	3600 (96.4)	6200 (166)	7000 (188)	6000 (161)	6850 (184)
	25	1.7	2550 (68.3)	5000 (134)	7350 (197)	8950 (240)	9000 (241)	
	60	4.1	4750 (127)	5100 (137)	7050 (189)	5600 (150) ⁽¹⁾		
	100	6.9	6650 (186)	7300 (196)	5200 (139) ⁽¹⁾			
125	8.6	6950 ()	8300 (222)					
7 inches w.c. (17 mbar) 655-697-004 1 inch w.c. (2 mbar) droop 2 inches w.c. (5 mbar) boost	0.4	0.028				900 (24.1)	1300 (34.8)	1450 (38.9)
	0.5	0.034				1200 (32.2)	1550 (41.5)	1750 (46.9)
	1	0.07	400 (10.7)	800 (21.4)	1100 (29.5)	1900 (50.9)	2300 (61.6)	2500 (67.0)
	1.5	0.10	500 (13.4)	1050 (28.1)	1500 (40.2)	2300 (61.6)	2800 (75.0)	1800 (48.2)
	2	0.14	600 (16.1)	1300 (34.8)	1900 (50.9)	2100 (56.3)	3300 (88.4)	1800 (48.2)
	5	0.34	950 (25.5)	2100 (56.3)	3200 (85.8)	3350 (89.8)	5100 (137)	4500 (121)
	13	0.90	1600 (42.8)	2200 (58.9)	3300 (88.4)	5800 (155)	8000 (214)	8000 (214)
	25	1.7	2200 (58.9)	5200 (139)	6800 (182)	8400 (225)	8750 (235)	
	60	4.1	4300 (115)	9200 (247)	10100 (271)	9900 (265)		
	100	6.9	7500 (201)	10500 (281)	9200 (247) ⁽¹⁾			
125	8.6	9050 (243)	9800 (263) ⁽¹⁾					
11 inches w.c. (17 mbar) 655-697-005 ± 2 inches w.c. (5 mbar)	0.5	0.03				800 (21.4)	1500 (40.2)	1700 (45.6)
	1	0.07	400 (10.7)	700 (18.7)	1100 (29.5)	1800 (48.2)	2200 (58.9)	2450 (65.7)
	1.5	0.10	500 (13.4)	950 (25.5)	1450 (38.9)	2300 (61.6)	2800 (75.0)	2600 (69.7)
	2	0.14	600 (16.1)	1200 (32.2)	1700 (45.6)	1950 (52.3)	3200 (85.8)	2750 (73.7)
	5	0.34	950 (25.5)	2000 (53.6)	2900 (77.7)	3800 (102)	5100 (137)	5150 (138)
	13	0.90	1600 (42.8)	3400 (91.1)	3700 (99.2)	6100 (163)	7250 (194)	7650 (205)
	25	1.7	2100 (56.3)	5150 (138)	7100 (190)	7950 (213)	9400 (252)	
	60	4.1	4400 (118)	9250 (248)	9400 (252)	10400 (279)		
	100	6.9	7300 (196)	10000 (268)	10100 (271)			
	125	8.6	9050 (243)	10800 (289)				
14 inches w.c. (35 mbar) 655-697-005 ± 2 inches w.c. (5 mbar)	1	0.07	450 (12.1)	800 (21.4)	1000 (26.8)	1250 (33.5)	1500 (40.2)	1950 (52.3)
	1.5	0.10	500 (13.4)	850 (22.8)	1050 (28.1)	1550 (41.5)	1650 (44.2)	2350 (62.9)
	2	0.14	550 (14.7)	1150 (30.8)	1400 (37.5)	1750 (46.9)	2300 (61.6)	2500 (67.0)
	5	0.34	1000 (26.8)	1200 (32.2)	2050 (54.9)	3000 (80.4)	4300 (115)	4750 (127)
	13	0.90	1750 (46.9)	3050 (81.7)	4250 (114)	6100 (163)	7300 (196)	7850 (210)
	25	1.7	2500 (67.0)	4750 (127)	5650 (151)	8700 (233)	8700 (233)	
	60	4.1	4750 (127)	9450 (253)	9950 (267)	10550 (283)		
	100	6.9	7450 (200)	10400 (279)	10600 (284)			
	125	8.6	9050 (243)	10450 (280)				
	20 inches w.c. (50 mbar) 655-697-006 ± 3 inches w.c. (7 mbar)	1	0.07	300 (8.04)	500 (13.4)	750 (20.1)	1000 (26.8)	1300 (34.8)
2		0.14	500 (13.4)	950 (25.5)	1400 (37.5)	2000 (53.6)	2800 (75.0)	3100 (83.1)
5		0.34	900 (24.1)	1700 (45.6)	2500 (67.0)	4200 (113)	5000 (134)	5500 (147)
13		0.90	1500 (40.2)	3200 (85.8)	5400 (145)	6500 (174)	7000 (188)	7100 (190)
25		1.7	2100 (56.3)	4700 (126)	7000 (188)	8250 (221)	9350 (251)	
60		4.1	4750 (127)	8900 (239)	9950 (267)	10600 (284)		
100		6.9	7400 (198)	10500 (281)	10800 (289)			
125		8.6	9200 (247)	10950 (293)				

1. Limited due to boost

 - Shaded areas show where indicated droop would be exceeded regardless of capacity.

 - Shaded areas show where maximum operating inlet pressure for a given port diameter is exceeded.

P203 Flow Capacities in SCFH (Nm³/h) of 0.6 Specific Gravity Natural Gas



Outlet Pressure, Spring Part Number, and Accuracy	Inlet Pressure		NPT 2 (DN 50) Body Size					
			Orifice Size, Inches (mm)					
	PSIG	BAR	1/4 (6.4)	3/8 (9.5)	1/2 (13)	3/4 (19)	1 (25)	1-3/16 (30)
4 inches w.c. (10 mbar) 655-697-002 or 655-697-003 1 inch w.c. (2 mbar) droop 2 inches w.c. (5 mbar) boost	0.4	0.028				1200 (32.3)	1600 (42.8)	1800 (48.2)
	0.5	0.034				1700 (45.6)	2200 (58.9)	2400 (64.3)
	1	0.07	400 (10.7)	900 (24.1)	1300 (34.8)	2800 (75.0)	3200 (85.8)	3800 (102)
	1.5	0.10	500 (13.4)	1100 (29.5)	1700 (45.5)	3600 (96.5)	4300 (115)	5000 (134)
	2	0.14	600 (16.1)	1400 (37.5)	2200 (58.9)	4500 (121)	5500 (147)	6400 (172)
	5	0.34	1000 (26.8)	2300 (61.6)	3700 (99.2)	7800 (209)	9500 (255)	12700 (340)
	13	0.90	1650 (44.2)	3700 (99.2)	6500 (174)	13000 (348)	14000 (375)	14500 (389)
	25	1.7	2500 (64.3)	5200 (139)	9200 (247)	13000 (348)	18000 (482)	
	60	4.1	4450 (119)	9000 (241)	14550 (390)	15000 (402)		
	100	6.9	5500 (147)	9500 (255)	12900 (346) ⁽¹⁾			
125	8.6	7250 (194)	3900 (105) ⁽¹⁾					
7 inches w.c. (17 mbar) 655-697-004 1 inch w.c. (2 mbar) droop 2 inches w.c. (5 mbar) boost	0.4	0.028				950 (25.5)	1400 (37.5)	1600 (42.8)
	0.5	0.034				1500 (40.2)	1800 (48.2)	2000 (53.6)
	1	0.07	400 (10.7)	800 (21.4)	1200 (32.2)	2300 (61.6)	2800 (75.0)	3300 (88.4)
	1.5	0.10	500 (13.4)	1050 (28.1)	1600 (42.8)	3100 (83.1)	3600 (96.5)	4500 (121)
	2	0.14	600 (16.1)	1300 (34.8)	2000 (53.6)	4000 (107)	4500 (121)	6000 (161)
	5	0.34	1000 (26.8)	2100 (56.3)	3500 (93.8)	7700 (206)	9400 (252)	9400 (252)
	13	0.90	1650 (44.2)	3500 (93.8)	6400 (172)	10000 (268)	20200 (541)	21200 (568)
	25	1.7	2400 (64.3)	5200 (139)	10300 (276)	20000 (536)	11800 (316) ⁽¹⁾	
	60	4.1	4450 (119)	9000 (241)	12000 (322)	20700 (555)		
	100	6.9	7500 (201)	10000 (268)	13100 (351)			
125	8.6	9500 (255)	10300 (276)					
11 inches w.c. (17 mbar) 655-697-005 ± 2 inches w.c. (5 mbar)	0.5	0.03				800 (21.4)	1500 (40.2)	1600 (42.8)
	1	0.07	400 (10.7)	750 (20.1)	1100 (29.5)	1800 (48.2)	2500 (64.0)	2600 (69.7)
	1.5	0.10	500 (13.4)	1000 (26.8)	1450 (38.9)	2500 (67.0)	3400 (91.1)	3350 (89.8)
	2	0.14	600 (16.1)	1200 (32.2)	1700 (45.6)	3100 (83.1)	3600 (113)	3750 (101)
	5	0.34	1000 (26.8)	2000 (53.6)	3000 (80.4)	7300 (196)	7000 (188)	8500 (228)
	13	0.90	1600 (42.9)	3400 (91.1)	6200 (166)	10350 (277)	17650 (473)	18100 (485)
	25	1.7	2400 (64.3)	5650 (151)	10350 (277)	19300 (517)	23450 (628)	
	60	4.1	4450 (119)	11350 (304)	19300 (517)	20200 (541)		
	100	6.9	7450 (200)	16650 (446)	20200 (541)			
	125	8.6	9500 (255)	17500 (469)				
14 inches w.c. (35 mbar) 655-697-005 ± 2 inches w.c. (5 mbar)	1	0.07	450 (12.1)	700 (18.8)	1100 (29.5)	1500 (40.2)	1700 (45.6)	2700 (72.4)
	1.5	0.10	550 (14.7)	850 (22.8)	1200 (32.3)	1900 (50.9)	2700 (72.4)	3600 (96.5)
	2	0.14	600 (16.1)	1000 (26.8)	1900 (50.9)	2800 (75.0)	3800 (102)	3800 (102)
	5	0.34	1050 (28.1)	1750 (46.9)	2800 (75.0)	4000 (107)	5300 (142)	10600 (284)
	13	0.90	1750 (46.9)	3700 (99.2)	5700 (153)	14400 (386)	18000 (482)	18500 (496)
	25	1.7	2600 (69.7)	5700 (153)	10200 (273)	18000 (482)	25400 (681)	
	60	4.1	4800 (129)	10900 (292)	11000 (295)	19600 (525)		
	100	6.9	7400 (198)	16500 (442)	14100 (378)			
	125	8.6	9100 (244)	18000 (482)				
	20 inches w.c. (50 mbar) 655-697-006 ± 3 inches w.c. (7 mbar)	1	0.07	300 (8.04)	750 (20.1)	550 (14.7)	1250 (33.5)	1700 (45.6)
2		0.14	500 (13.4)	1150 (30.8)	1700 (45.6)	1900 (50.9)	2350 (62.9)	3250 (87.1)
5		0.34	900 (24.1)	1650 (44.2)	2150 (57.6)	3250 (87.1)	6400 (172)	6700 (180)
13		0.90	1500 (40.2)	2550 (68.3)	4350 (117)	5950 (159)	10150 (272)	10500 (281)
25		1.7	2450 (65.7)	4850 (130)	7200 (193)	18100 (485)	19200 (515)	
60		4.1	4900 (131)	9400 (252)	19600 (525)	22700 (608)		
100		6.9	7500 (201)	17400 (466)	13800 (370)			
125		8.6	9150 (245)	5500 (147) ⁽¹⁾				

P203 Flow Capacities in SCFH (Nm³/h) of 0.6 Specific Gravity Natural Gas

Outlet Pressure, Spring Part Number, and Accuracy	Inlet Pressure		NPT 1-1/2 Body Size					
			Orifice Size, Inches (mm)					
	PSIG	BAR	1/4 (6.4)	3/8 (9.5)	1/2 (13)	3/4 (19)	1 (25)	1-3/16 (30)
1 PSIG (0.07 BAR) 655-697-006 ±0.2 PSIG (0.014 BAR)	2	0.14	700 (18.8)	1250 (33.5)	1550 (41.5)	2900 (77.7)	3050 (81.7)	3250 (87.1)
	5	0.34	1050 (28.1)	2150 (57.6)	2800 (75.0)	4800 (129)	5600 (150)	6300 (169)
	10	0.69	1650 (44.2)	3200 (85.8)	4400 (118)	6550 (176)	7800 (209)	8150 (218)
	15	1.0	2000 (53.6)	4100 (110)	5750 (154)	8000 (214)	9400 (252)	10250 (275)
	20	1.4	2300 (61.6)	4750 (127)	6100 (163)	8700 (233)	10950 (293)	
	25	1.7	2600 (69.7)	5500 (147)	8200 (220)	9950 (267)	11550 (310)	
	30	2.1	2900 (77.7)	6250 (168)	8350 (224)	10800 (289)	12250 (328)	
	40	2.8	3600 (96.5)	7500 (201)	9350 (251)	10850 (291)		
	45	3.1	3900 (105)	8400 (225)	10350 (277)	11000 (295)		
	50	3.5	4250 (114)	8900 (239)	10950 (293)	11050 (296)		
	60	4.1	4950 (133)	10000 (268)	11000 (295)	11400 (306)		
	80	5.5	6150 (165)	11150 (299)	11350 (304)			
	100	6.9	7500 (201)	12000 (322)	12000 (322)			
	125	8.6	9150 (245)	12000 (322)				
1 PSIG (0.07 BAR) 655-697-006 ± 1% ABS ±0.16 psia (0.011 BAR)	2	0.14	650 (17.4)	1050 (28.1)	1350 (36.2)	2450 (65.7)	2700 (72.4)	3000 (80.4)
	5	0.34	1050 (28.1)	2100 (56.3)	2700 (72.4)	3800 (102)	4700 (126)	5200 (139)
	10	0.69	1500 (40.2)	2800 (75.0)	3700 (99.2)	5600 (150)	7000 (188)	7300 (196)
	15	1.0	1950 (52.3)	3750 (101)	4900 (131)	6900 (185)	8500 (228)	8750 (235)
	20	1.4	2200 (58.9)	4600 (123)	5800 (155)	8150 (218)	10350 (277)	
	25	1.7	2500 (67.0)	5000 (134)	7250 (194)	9050 (243)	10850 (291)	
	30	2.1	2800 (75.0)	6000 (161)	8200 (220)	9400 (252)	11000 (295)	
	40	2.8	3550 (95.1)	7350 (197)	9100 (244)	9500 (255)		
	45	3.1	3900 (105)	8250 (221)	9650 (259)	10100 (271)		
	50	3.5	4050 (109)	8450 (226)	10300 (276)	10300 (276)		
	60	4.1	4800 (129)	9050 (243)	10450 (280)	10550 (283)		
	80	5.5	5900 (158)	11000 (295)	11100 (297)			
	100	6.9	7400 (198)	11150 (299)	11500 (299)			
	125	8.6	9000 (241)	11750 (315)				
1 PSIG (0.07 BAR) 655-697-006 ± 2% ABS ±0.31 psia (0.021 BAR)	2	0.14	750 (20.1)	1450 (38.9)	2100 (56.3)	3700 (99.2)	4650 (125)	5350 (143)
	5	0.34	1250 (33.5)	2500 (67.0)	3550 (95.1)	6050 (162)	7900 (212)	7900 (212)
	10	0.69	1750 (46.9)	3450 (92.5)	5100 (137)	8550 (229)	9550 (256)	10100 (271)
	15	1.0	2050 (54.9)	4350 (117)	6700 (180)	9400 (252)	11250 (302)	11400 (306)
	20	1.4	2500 (67.0)	5150 (138)	8100 (217)	10500 (281)	12200 (327)	
	25	1.7	2700 (72.4)	5800 (155)	10100 (271)	11550 (310)	12600 (338)	
	30	2.1	3050 (81.7)	6650 (178)	10550 (283)	12350 (331)	13100 (351)	
	40	2.8	3700 (99.2)	7950 (212)	10550 (283)	12350 (331)		
	45	3.1	4100 (110)	8800 (236)	11800 (316)	12700 (340)		
	50	3.5	4550 (122)	9250 (248)	12000 (322)	13000 (348)		
	60	4.1	5000 (134)	10900 (292)	12600 (338)	13000 (348)		
	80	5.5	6450 (173)	12550 (336)	13000 (348)			
	100	6.9	7950 (213)	12900 (346)	13450 (360)			
	125	8.6	9450 (253)	13450 (360)				
1 PSIG (0.07 BAR) 655-697-006 ±0.2 PSIG (0.014 BAR)	2	0.14	500 (13.4)	750 (20.1)	1750 (46.9)	2250 (60.3)	2400 (64.3)	2850 (76.4)
	5	0.34	1100 (29.5)	1800 (48.2)	2300 (61.6)	3400 (91.1)	4850 (130)	5350 (143)
	10	0.69	1600 (42.9)	3200 (85.8)	4600 (123)	7250 (194)	8800 (236)	8800 (236)
	30	2.1	2800 (75.0)	6300 (169)	7800 (209)	10400 (279)	11250 (302)	
	60	4.1	4900 (131)	9600 (257)	9650 (259)	11000 (295)		
	100	6.9	7300 (196)	11200 (300)	11950 (320)			
	125	8.6	9100 (244)	10550 (283) ⁽¹⁾				

1. Limited due to boost

 - Shaded areas show where maximum operating inlet pressure for a given port diameter is exceeded.

P203 Flow Capacities in SCFH (Nm³/h) of 0.6 Specific Gravity Natural Gas



Outlet Pressure, Spring Part Number, and Accuracy	Inlet Pressure		NPT 2 (DN 50) Body Size					
			Orifice Size, Inches (mm)					
	PSIG	BAR	1/4 (6.4)	3/8 (9.5)	1/2 (13)	3/4 (19)	1 (25)	1-3/16 (30)
1 PSIG (0.07 BAR) 655-697-006 ±0.2 PSIG (0.014 BAR)	2	0.14	650 (17.4)	1200 (32.2)	2200 (58.9)	3200 (85.8)	3600 (96.5)	4500 (121)
	5	0.34	1100 (25.5)	2300 (61.6)	3200 (85.8)	4800 (129)	7700 (206)	10000 (268)
	10	0.69	1600 (42.9)	3000 (80.4)	4300 (115)	11400 (306)	15200 (407)	16300 (437)
	15	1.0	1900 (50.9)	4000 (107)	6900 (185)	15600 (418)	20800 (557)	22300 (598)
	20	1.4	2300 (61.6)	4900 (131)	9100 (244)	19000 (509)	24000 (643)	
	25	1.7	2600 (69.7)	5600 (150)	10500 (281)	21700 (582)	27400 (734)	
	30	2.1	2900 (77.7)	6500 (174)	11800 (316)	25300 (678)	32800 (879)	
	40	2.8	3700 (99.2)	8000 (214)	14500 (389)	27000 (724)		
	45	3.1	4000 (107)	8800 (236)	15800 (423)	27000 (724)		
	50	3.5	4300 (115)	9300 (249)	16600 (445)	28000 (750)		
	60	4.1	4900 (131)	11300 (303)	19500 (523)	31600 (847)		
	80	5.5	6300 (169)	14200 (381)	24000 (643)			
	100	6.9	7700 (206)	16700 (448)	29500 (791)			
125	8.6	9600 (257)	20200 (541)					
1 PSIG (0.07 BAR) 655-697-006 ± 1% ABS ±0.16 psia (0.011 BAR)	2	0.14	570 (15.3)	1100 (29.5)	2000 (53.6)	2750 (73.7)	3100 (83.1)	4000 (107)
	5	0.34	1050 (28.1)	2200 (58.9)	2750 (73.7)	4100 (110)	6250 (168)	9000 (241)
	10	0.69	1500 (40.2)	2500 (67.0)	4050 (109)	8500 (228)	13250 (355)	13700 (367)
	15	1.0	1900 (50.9)	3450 (92.5)	5800 (155)	15500 (415)	16000 (429)	16300 (437)
	20	1.4	2300 (61.6)	4800 (129)	7700 (206)	18300 (490)	20850 (559)	
	25	1.7	2500 (67.0)	5600 (150)	10400 (279)	21500 (576)	22800 (611)	
	30	2.1	2900 (77.7)	6350 (170)	11950 (320)	23800 (638)	24300 (651)	
	40	2.8	3650 (97.8)	7850 (210)	14550 (390)	24300 (651)		
	45	3.1	3850 (103)	8400 (225)	15600 (418)	25400 (681)		
	50	3.5	4250 (114)	9350 (251)	16700 (448)	26000 (697)		
	60	4.1	4900 (131)	11200 (300)	19400 (520)	32000 (858)		
	80	5.5	6200 (166)	14250 (382)	24600 (659)			
	100	6.9	7400 (198)	16750 (449)	29000 (777)			
125	8.6	9350 (251)	20200 (541)					
1 PSIG (0.07 BAR) 655-697-006 ± 2% ABS ±0.31 psia (0.021 BAR)	2	0.14	700 (18.8)	1450 (38.9)	2450 (65.7)	4100 (110)	5600 (150)	7900 (212)
	5	0.34	1150 (30.8)	2550 (68.3)	4000 (107)	8000 (214)	11700 (314)	14300 (383)
	10	0.69	1800 (48.2)	3550 (95.1)	6200 (166)	12300 (330)	18400 (493)	20000 (536)
	15	1.0	2050 (54.9)	4450 (119)	7850 (210)	15900 (426)	22000 (590)	24600 (659)
	20	1.4	2400 (64.3)	5250 (141)	9100 (244)	19200 (515)	25800 (691)	
	25	1.7	2750 (73.7)	5900 (158)	10300 (276)	21800 (584)	31200 (836)	
	30	2.1	3150 (84.4)	6550 (176)	11800 (316)	26200 (702)	35000 (938)	
	40	2.8	3750 (101)	8200 (220)	14300 (383)	30500 (817)		
	45	3.1	4050 (109)	8800 (236)	15600 (418)	28100 (753)		
	50	3.5	4400 (118)	9300 (249)	16700 (448)	33900 (909)		
	60	4.1	5050 (135)	10850 (291)	19500 (523)	34200 (917)		
	80	5.5	6350 (170)	13600 (364)	24600 (659)			
	100	6.9	7850 (210)	17000 (456)	30200 (809)			
125	8.6	9400 (252)	20500 (549)					
1 PSIG (0.07 BAR) 655-697-006 ±0.2 PSIG (0.014 BAR)	2	0.14	500 (13.4)	1050 (28.1)	1400 (37.5)	2200 (58.9)	2900 (77.7)	3700 (99.2)
	5	0.34	1100 (29.5)	2000 (53.6)	2200 (58.9)	4500 (121)	6600 (177)	7000 (188)
	10	0.69	1600 (42.9)	3500 (93.8)	5700 (153)	9700 (260)	13000 (348)	13300 (356)
	30	2.1	2800 (75.0)	6200 (166)	11700 (314)	20000 (536)	23000 (616)	
	60	4.1	4900 (131)	10900 (292)	19300 (517)	20600 (552)		
	100	6.9	7500 (201)	17300 (464)	23900 (641)			
	125	8.6	9000 (241)	19900 (533)				

1. Limited due to boost

- Shaded areas show where maximum operating inlet pressure for a given port diameter is exceeded.

P203 H Flow Capacities in SCFH (Nm³/h) of 0.6 Specific Gravity Natural Gas

Outlet Pressure, Spring Part Number, and Accuracy	Inlet Pressure		NPT 1-1/2 Body Size					
			Orifice Size, Inches (mm)					
	PSIG	BAR	1/4 (6.4)	3/8 (9.5)	1/2 (13)	3/4 (19)	1 (25)	1-3/16 (30)
2 PSIG (0.14 BAR) 655-697-007 ±0.2 PSIG (0.014 BAR)	5	0.34	850 (22.8)	1600 (42.9)	1650 (44.2)	2400 (64.3)	2450 (65.7)	3900 (105)
	10	0.69	1450 (38.9)	2050 (54.9)	3250 (87.1)	5400 (145)	5750 (154)	6650 (178)
	15	1.0	1650 (44.2)	3000 (80.4)	4300 (115)	7000 (188)	8200 (220)	8200 (220)
	20	1.4	2050 (54.9)	3850 (103)	5650 (151)	7500 (201)	9050 (243)	
	25	1.7	2500 (67.0)	4600 (123)	6500 (174)	9600 (257)	9700 (260)	
	30	2.1	2750 (73.7)	5650 (151)	6500 (174)	9600 (257)	10850 (291)	
	40	2.8	3500 (93.8)	7000 (188)	8400 (225)	10150 (272)		
	45	3.1	3750 (101)	7800 (209)	9150 (245)	10500 (281)		
	50	3.5	4250 (114)	8500 (228)	9600 (257)	10500 (281)		
	60	4.1	4850 (130)	8800 (236)	9700 (260)	11400 (306)		
	80	5.5	6150 (165)	10000 (268)	11250 (302)			
	100	6.9	7600 (204)	10800 (289)	11250 (302)			
	125	8.6	9300 (249)	12200 (327)				
2 PSIG (0.14 BAR) 655-697-007 ± 1% ABS ±0.04 psia (0.028 BAR)	5	0.34	1100 (29.5)	2200 (58.9)	2800 (75.0)	4550 (122)	5600 (150)	6550 (176)
	10	0.69	1750 (46.9)	3150 (84.4)	4600 (123)	7550 (202)	9050 (243)	10150 (272)
	15	1.0	2000 (53.6)	4200 (113)	6400 (172)	10050 (269)	11000 (295)	11200 (300)
	20	1.4	2400 (64.3)	5000 (134)	7550 (202)	11700 (314)	12200 (327)	
	25	1.7	2700 (72.4)	5750 (154)	9600 (257)	11900 (319)	12950 (347)	
	30	2.1	3100 (83.1)	6700 (180)	9600 (257)	11900 (319)	13300 (356)	
	40	2.8	3750 (101)	7950 (213)	10750 (288)	13000 (348)		
	45	3.1	4100 (110)	8750 (235)	10750 (288)	13000 (348)		
	50	3.5	4550 (122)	9550 (256)	12700 (340)	13000 (348)		
	60	4.1	5150 (138)	11250 (302)	13300 (356)	14400 (386)		
	80	5.5	6450 (173)	12750 (342)	13300 (356)			
	100	6.9	7750 (208)	14450 (387)	13300 (356)			
	125	8.6	9400 (252)	14600 (391)				
2 PSIG (0.14 BAR) 655-697-007 ± 1% ABS ±0.17 psia (0.012 BAR)	5	0.34	850 (22.8)	1400 (37.5)	1450 (38.9)	2250 (60.3)	2450 (65.7)	3300 (88.4)
	10	0.69	1400 (37.5)	1650 (44.2)	2550 (68.3)	4350 (117)	5250 (141)	5600 (150)
	15	1.0	1500 (40.2)	2700 (72.4)	3800 (102)	6000 (161)	5400 (145)	8000 (214)
	20	1.4	2000 (53.6)	3600 (96.5)	5200 (139)	7200 (193)	8200 (220)	
	25	1.7	2400 (64.3)	4500 (121)	6400 (172)	9000 (241)	9550 (256)	
	30	2.1	2800 (75.0)	5600 (150)	7500 (201)	10000 (268)	10400 (279)	
	40	2.8	3600 (96.5)	7800 (209)	9200 (247)	10150 (272)		
	45	3.1	3900 (105)	8400 (225)	9800 (263)	10900 (292)		
	50	3.5	4300 (115)	9100 (244)	10300 (276)	10600 (284)		
	60	4.1	5000 (134)	10200 (273)	11400 (306)	11300 (303)		
	80	5.5	6400 (172)	12000 (322)	10300 (276)(1)			
	100	6.9	7900 (212)	13000 (348)	11150 (299)(1)			
	125	8.6	9600 (257)	11950 (320)(1)				
2 PSIG (0.14 BAR) 655-697-007 ± 2% ABS ±0.33 psia (0.023 BAR)	5	0.34	1050 (28.1)	2100 (56.3)	2500 (67.0)	4100 (110)	5200 (139)	6250 (168)
	10	0.69	1650 (44.2)	3050 (81.7)	4200 (113)	6400 (172)	8350 (224)	8850 (237)
	15	1.0	1900 (50.9)	4200 (113)	6200 (166)	8800 (236)	10500 (281)	10750 (288)
	20	1.4	2200 (58.9)	5100 (137)	7600 (204)	10300 (276)	12000 (322)	
	25	1.7	2500 (67.0)	5800 (155)	8700 (233)	11800 (316)	12050 (323)	
	30	2.1	3000 (80.4)	6500 (174)	9600 (257)	12600 (338)	12700 (340)	
	40	2.8	3600 (96.5)	8100 (217)	11500 (308)	12700 (340)		
	45	3.1	3900 (105)	8800 (236)	12000 (322)	12800 (343)		
	50	3.5	4300 (115)	9700 (260)	12600 (338)	12900 (346)		
	60	4.1	5000 (134)	11300 (303)	13600 (364)	13700 (367)		
	80	5.5	6400 (172)	14200 (381)	12650 (339)			
	100	6.9	7900 (212)	15500 (415)	12950 (347)			
	125	8.6	9600 (257)	14200 (381)(1)				

1. Limited due to boost

 - Shaded areas show where maximum operating inlet pressure for a given port diameter is exceeded.

P203 H Flow Capacities in SCFH (Nm³/h) of 0.6 Specific Gravity Natural Gas



Outlet Pressure, Spring Part Number, and Accuracy	Inlet Pressure		NPT 2 (DN 50) Body Size					
			Orifice Size, Inches (mm)					
	PSIG	BAR	1/4 (6.4)	3/8 (9.5)	1/2 (13)	3/4 (19)	1 (25)	1-3/16 (30)
2 PSIG (0.14 BAR) 655-697-007 ±0.2 PSIG (0.014 BAR)	5	0.34	850 (22.8)	1800 (48.2)	1800 (48.2)	2950 (79.1)	4250 (114)	5200 (139)
	10	0.69	1350 (36.2)	1900 (50.9)	3000 (80.4)	5200 (139)	6600 (177)	7800 (209)
	15	1.0	1700 (45.6)	2800 (75.0)	3700 (99.2)	6900 (185)	7200 (193)	9500 (255)
	20	1.4	2000 (53.6)	3800 (102)	5300 (142)	9000 (241)	9800 (263)	
	25	1.7	2450 (65.7)	4500 (121)	6800 (182)	12500 (335)	14200 (381)	
	30	2.1	2650 (71.0)	5200 (139)	7500 (201)	16000 (429)	16100 (431)	
	40	2.8	3400 (91.1)	7400 (198)	13200 (354)	21600 (579)		
	45	3.1	3600 (96.1)	8000 (214)	15500 (415)	21600 (579)		
	50	3.5	4000 (107)	8500 (228)	16700 (448)	21900 (587)		
	60	4.1	4600 (123)	10700 (287)	19200 (515)	18800 (504) ⁽¹⁾		
	80	5.5	5800 (155)	13100 (351)	24800 (665)			
	100	6.9	7100 (190)	16200 (434)	25600 (686)			
	125	8.6	9000 (241)	19900 (533)				
2 PSIG (0.14 BAR) 655-697-007 ±0.4 PSIG (0.028 BAR)	5	0.34	1100 (29.5)	2250 (60.3)	3200 (85.8)	5500 (147)	7800 (209)	10100 (271)
	10	0.69	1600 (42.9)	3250 (87.1)	5400 (145)	10000 (268)	14100 (378)	15100 (405)
	15	1.0	2000 (53.6)	4150 (111)	7200 (193)	14400 (386)	18600 (498)	22100 (592)
	20	1.4	2300 (61.6)	4950 (133)	9000 (241)	17500 (469)	24000 (643)	
	25	1.7	2650 (71.0)	5800 (155)	10200 (273)	20700 (555)	28000 (750)	
	30	2.1	3100 (83.1)	6600 (177)	11800 (316)	24900 (667)	28500 (764)	
	40	2.8	3600 (96.5)	8100 (217)	14600 (391)	28000 (750)		
	45	3.1	4100 (110)	8850 (237)	15800 (423)	29000 (777)		
	50	3.5	4400 (118)	9850 (264)	17200 (461)	29200 (783)		
	60	4.1	4900 (131)	11300 (303)	19500 (523)	29300 (785)		
	80	5.5	6400 (172)	14300 (383)	24500 (657)			
	100	6.9	7600 (204)	17200 (461)	29700 (796)			
	125	8.6	9400 (252)	20500 (549)				
2 PSIG (0.14 BAR) 655-697-007 ± 1% ABS ±0.17 psia (0.012 BAR)	5	0.34	750 (20.1)	1600 (42.9)	1600 (42.9)	2400 (64.3)	3000 (80.4)	4100 (110)
	10	0.69	1250 (33.5)	1600 (42.9)	2550 (68.3)	4250 (114)	5000 (134)	6100 (163)
	15	1.0	1600 (42.9)	2700 (72.4)	3800 (102)	5200 (139)	6900 (185)	7600 (204)
	20	1.4	2000 (53.6)	3600 (96.5)	5200 (139)	6900 (185)	9400 (252)	
	25	1.7	2450 (65.7)	4400 (118)	7500 (201)	9600 (257)	10650 (285)	
	30	2.1	2800 (75.0)	5200 (139)	8600 (230)	11800 (316)	16100 (431)	
	40	2.8	3700 (99.2)	7500 (201)	12200 (327)	16200 (434)		
	45	3.1	4100 (110)	8400 (225)	15200 (407)	18350 (492)		
	50	3.5	4400 (118)	9000 (241)	16900 (453)	21000 (563)		
	60	4.1	5100 (137)	11000 (295)	20800 (557)	21000 (563)		
	80	5.5	6500 (174)	14600 (391)	24800 (665)			
	100	6.9	8000 (214)	18000 (482)	29300 (785)			
	125	8.6	9800 (263)	20500 (549)				
2 PSIG (0.14 BAR) 655-697-007 ± 2% ABS ±0.33 psia (0.023 BAR)	5	0.34	1000 (26.8)	2150 (57.6)	2750 (73.7)	5000 (134)	6200 (166)	7900 (212)
	10	0.69	1550 (41.5)	3050 (81.7)	5000 (134)	8600 (230)	12750 (342)	13800 (370)
	15	1.0	1900 (50.9)	4200 (113)	7200 (193)	11000 (295)	11750 (315)	21700 (582)
	20	1.4	2300 (61.6)	5100 (137)	9200 (247)	14200 (381)	16000 (429)	
	25	1.7	2600 (69.7)	5900 (158)	10700 (287)	16400 (440)	25400 (681)	
	30	2.1	3000 (80.4)	6600 (177)	12100 (324)	19700 (528)	27900 (748)	
	40	2.8	3700 (99.2)	8200 (220)	12200 (327)	27200 (729)		
	45	3.1	4100 (110)	9000 (241)	15200 (407)	27200 (729)		
	50	3.5	4400 (118)	9700 (260)	16900 (453)	27400 (734)		
	60	4.1	5100 (137)	11300 (303)	20800 (557)	27400 (734)		
	80	5.5	6500 (174)	14600 (391)	24500 (657)			
	100	6.9	8000 (214)	18000 (482)	29600 (793)			
	125	8.6	9800 (263)	20500 (549)				

1. Limited due to boost

- Shaded areas show where maximum operating inlet pressure for a given port diameter is exceeded.

P203 H Flow Capacities in SCFH (Nm³/h) of 0.6 Specific Gravity Natural Gas

Outlet Pressure, Spring Part Number, and Accuracy	Inlet Pressure		NPT 1-1/2 Body Size					
			Orifice Size, Inches (mm)					
	PSIG	BAR	1/4 (6.4)	3/8 (9.5)	1/2 (13)	3/4 (19)	1 (25)	1-3/16 (30)
3 PSIG (0.21 BAR) 655-697-008 ±0.3 PSIG (0.021 BAR)	5	0.34	800 (21.4)	1350 (36.2)	1650 (44.2)	2500 (67.0)	2500 (67.0)	3850 (103)
	10	0.69	1200 (32.2)	1800 (48.2)	2650 (71.0)	4600 (123)	6050 (162)	6600 (177)
	15	1.0	1650 (44.2)	2300 (61.6)	3750 (101)	5600 (174)	9200 (247)	8200 (220)
	20	1.4	1950 (52.3)	3500 (93.8)	5000 (134)	8350 (224)	9200 (247)	
	25	1.7	2150 (57.6)	4400 (118)	6500 (174)	8150 (218)	10050 (269)	
	30	2.1	2700 (72.4)	5600 (150)	6700 (180)	10050 (269)	11250 (302)	
	40	2.8	3300 (88.4)	6900 (185)	7900 (212)	10300 (275)		
	45	3.1	3550 (95.1)	7000 (188)	8650 (232)	11000 (295)		
	50	3.5	4050 (109)	7800 (209)	9700 (260)	11000 (295)		
	60	4.1	4250 (114)	8200 (220)	9900 (265)	11450 (307)		
	80	5.5	5950 (159)	10000 (268)	11600 (311)			
	100	6.9	7450 (200)	11750 (315)	11900 (319)			
	125	8.6	8800 (236)	12200 (327)				
3 PSIG (0.21 BAR) 655-697-008 ±0.6 PSIG (0.041 BAR)	5	0.34	1100 (29.5)	1950 (52.3)	2800 (75.0)	4250 (114)	5400 (145)	7200 (193)
	10	0.69	1650 (44.2)	3100 (83.1)	4650 (125)	7750 (208)	8700 (233)	9100 (244)
	15	1.0	2050 (54.9)	4100 (110)	5950 (159)	9550 (256)	11150 (299)	11800 (316)
	20	1.4	2400 (64.3)	4900 (131)	7800 (209)	10650 (285)	12350 (331)	
	25	1.7	2600 (69.7)	5750 (154)	8700 (233)	11950 (320)	14050 (377)	
	30	2.1	3100 (83.1)	6550 (176)	10250 (275)	12050 (323)	14400 (386)	
	40	2.8	3150 (84.4)	7850 (210)	11300 (303)	13800 (370)		
	45	3.1	4150 (111)	8400 (225)	12450 (334)	14150 (379)		
	50	3.5	4400 (118)	9300 (249)	12450 (334)	14150 (379)		
	60	4.1	5000 (134)	10700 (287)	13000 (348)	15350 (411)		
	80	5.5	6400 (172)	13050 (350)	16000 (429)			
	100	6.9	7650 (205)	15400 (413)	16050 (430)			
	125	8.6	9200 (247)	16050 (430)				
3 PSIG (0.21 BAR) 655-697-008 ± 1% ABS ±0.18 psia (0.012 BAR)	5	0.34	500 (13.4)	1150 (30.8)	1200 (32.2)	1450 (38.9)	1550 (41.5)	2100 (56.3)
	10	0.69	900 (24.1)	1350 (36.2)	1500 (40.2)	2750 (73.7)	3200 (85.8)	3400 (91.1)
	15	1.0	1200 (32.2)	1700 (45.6)	2200 (58.9)	3900 (105)	4900 (131)	4950 (133)
	20	1.4	1500 (40.2)	2100 (56.3)	2900 (77.7)	5300 (142)	8000 (214)	
	25	1.7	1900 (50.9)	2600 (69.7)	4300 (115)	7400 (198)	9350 (251)	
	30	2.1	2200 (58.9)	3100 (83.1)	5100 (137)	8400 (225)	8650 (232) ⁽¹⁾	
	40	2.8	2900 (77.7)	4800 (129)	8000 (214)	8750 (235)		
	45	3.1	3300 (88.4)	5800 (155)	9300 (249)	9900 (265)		
	50	3.5	3700 (99.2)	6800 (182)	10200 (273)	10600 (284)		
	60	4.1	4400 (118)	8400 (225)	11600 (311)	10700 (287)		
	80	5.5	6300 (169)	10800 (289)	9400 (252) ⁽¹⁾			
	100	6.9	8100 (217)	12100 (324)	11750 (315)			
	125	8.6	10000 (268)	10750 (288) ⁽¹⁾				
3 PSIG (0.21 BAR) 655-697-008 ± 2% ABS ±0.35 psia (0.024 BAR)	5	0.34	900 (24.1)	1450 (38.9)	1800 (48.2)	3000 (80.4)	3000 (80.4)	4650 (125)
	10	0.69	1250 (33.5)	2050 (54.9)	3150 (84.4)	5150 (138)	6450 (173)	6650 (178)
	15	1.0	1800 (48.2)	3100 (83.1)	4400 (118)	7200 (193)	8700 (233)	8700 (233)
	20	1.4	2200 (58.9)	3800 (102)	6100 (163)	8600 (230)	11000 (295)	
	25	1.7	2600 (69.7)	5000 (134)	7600 (204)	9700 (260)	11050 (296)	
	30	2.1	2900 (77.7)	5800 (155)	8700 (233)	11200 (300)	11450 (3070)	
	40	2.8	3600 (96.5)	7800 (209)	10800 (289)	11600 (311)		
	45	3.1	4000 (107)	8400 (225)	11600 (311)	11600 (311)		
	50	3.5	4600 (123)	9400 (252)	12400 (332)	11750 (315)		
	60	4.1	5100 (137)	10600 (284)	13800 (370)	13250 (355)		
	80	5.5	6500 (174)	12700 (340)	12600 (338) ⁽¹⁾			
	100	6.9	8100 (217)	14400 (386)	12550 (336) ⁽¹⁾			
	125	8.6	10000 (268)	12500 (335) ⁽¹⁾				

1. Limited due to boost

 - Shaded areas show where maximum operating inlet pressure for a given port diameter is exceeded.

P203 H Flow Capacities in SCFH (Nm³/h) of 0.6 Specific Gravity Natural Gas



Outlet Pressure, Spring Part Number, and Accuracy	Inlet Pressure		NPT 2 (DN 50) Body Size					
			Orifice Size, Inches (mm)					
	PSIG	BAR	1/4 (6.4)	3/8 (9.5)	1/2 (13)	3/4 (19)	1 (25)	1-3/16 (30)
3 PSIG (0.21 BAR) 655-697-008 ±0.3 PSIG (0.021 BAR)	5	0.34	750 (20.1)	1400 (37.5)	1600 (42.9)	2400 (64.3)	2900 (77.7)	3500 (93.8)
	10	0.69	1200 (32.2)	1900 (50.9)	2750 (73.7)	5000 (134)	6400 (171)	6900 (185)
	15	1.0	1400 (37.5)	2000 (53.6)	3100 (83.1)	5900 (158)	7700 (206)	9800 (263)
	20	1.4	1850 (49.6)	3000 (80.4)	4150 (111)	7700 (206)	7900 (212)	
	25	1.7	2050 (54.9)	3900 (105)	5000 (134)	9100 (244)	9750 (261)	
	30	2.1	2550 (68.3)	4800 (129)	6700 (180)	10100 (271)	17200 (461)	
	40	2.8	3150 (84.4)	6250 (168)	8700 (233)	11600 (311)		
	45	3.1	3400 (91.1)	6750 (181)	9900 (265)	14500 (389)		
	50	3.5	3900 (105)	6750 (181)	12300 (330)	13900 (373)		
	60	4.1	4350 (117)	9400 (252)	12700 (340)	18300 (490)		
	80	5.5	5600 (150)	12700 (340)	18800 (504)			
	100	6.9	7000 (188)	14800 (397)	18800 (504)			
	125	8.6	8650 (232)	18800 (504)				
3 PSIG (0.21 BAR) 655-697-008 ±0.6 PSIG (0.041 BAR)	5	0.34	1100 (29.5)	1950 (52.3)	2550 (68.3)	4700 (126)	6000 (161)	7450 (200)
	10	0.69	1550 (41.5)	3000 (80.4)	4750 (127)	8600 (230)	12200 (327)	15400 (413)
	15	1.0	2050 (54.9)	3850 (103)	5950 (159)	12500 (338)	16200 (434)	20300 (544)
	20	1.4	2400 (64.3)	4850 (130)	8200 (220)	17000 (456)	21800 (584)	
	25	1.7	2800 (75.0)	5750 (154)	9800 (263)	19700 (528)	23000 (616)	
	30	2.1	3150 (84.4)	6450 (173)	11600 (311)	22500 (603)	26500 (710)	
	40	2.8	3650 (97.8)	7850 (210)	14300 (383)	26400 (708)		
	45	3.1	4100 (110)	8900 (239)	15500 (415)	28500 (764)		
	50	3.5	4350 (117)	9450 (253)	17000 (456)	29600 (793)		
	60	4.1	5100 (137)	11100 (297)	19850 (532)	29900 (801)		
	80	5.5	6350 (170)	14350 (385)	25200 (675)			
	100	6.9	7250 (194)	17250 (462)	29400 (788)			
	125	8.6	9400 (252)	21000 (563)				
3 PSIG (0.21 BAR) 655-697-008 ± 1% ABS ±0.18 psia (0.012 BAR)	5	0.34	650 (17.4)	1100 (29.3)	790 (21.2)	1500 (40.2)	1700 (45.6)	1750 (46.9)
	10	0.69	1000 (26.8)	1250 (33.5)	1500 (40.2)	2500 (67.0)	3700 (99.2)	4300 (115)
	15	1.0	1250 (33.5)	1750 (46.9)	2000 (53.6)	2900 (77.7)	3750 (101)	6000 (161)
	20	1.4	1450 (38.9)	2400 (64.3)	2200 (58.9)	4100 (110)	5750 (154)	
	25	1.7	1600 (42.8)	2900 (77.7)	4000 (107)	6900 (185)	6400 (172)	
	30	2.1	1950 (52.3)	3550 (95.1)	4400 (118)	8700 (233)	6700 (180)	
	40	2.8	2700 (72.4)	3850 (103)	5500 (147)	6450 (173)		
	45	3.1	2900 (77.7)	5400 (145)	9000 (241)	8000 (214)		
	50	3.5	3300 (88.4)	5700 (153)	9100 (244)	7900 (212)		
	60	4.1	3900 (105)	7200 (193)	11500 (308)	10300 (276)		
	80	5.5	5250 (141)	9200 (247)	9800 (263) ⁽¹⁾			
	100	6.9	6250 (168)	11300 (303)	10900 (292) ⁽¹⁾			
	125	8.6	7750 (208)	12650 (339)				
3 PSIG (0.21 BAR) 655-697-008 ± 2% ABS ±0.35 psia (0.024 BAR)	5	0.34	800 (21.4)	1450 (38.9)	1700 (45.6)	3150 (84.4)	3250 (87.1)	4000 (107)
	10	0.69	1300 (34.8)	2150 (57.6)	3200 (85.8)	5550 (149)	7200 (193)	9000 (241)
	15	1.0	1550 (41.5)	2850 (76.4)	4050 (109)	6800 (182)	8250 (221)	10800 (289)
	20	1.4	1850 (49.6)	3300 (88.4)	5400 (145)	9300 (249)	10900 (292)	
	25	1.7	2350 (62.9)	4650 (125)	6700 (180)	11250 (302)	15600 (418)	
	30	2.1	2450 (65.7)	5100 (137)	8600 (230)	12250 (328)	17350 (465)	
	40	2.8	3150 (84.4)	6950 (186)	11400 (306)	15150 (406)		
	45	3.1	3400 (91.1)	7650 (205)	11900 (319)	18150 (486)		
	50	3.5	3800 (102)	8500 (228)	14000 (375)	20200 (541)		
	60	4.1	4300 (115)	9850 (264)	19000 (509)	21150 (567)		
	80	5.5	5500 (147)	12600 (338)	23100 (619)			
	100	6.9	6500 (174)	15500 (415)	23650 (634)			
	125	8.6	8100 (217)	20650 (553)				

1. Limited due to boost

- Shaded areas show where maximum operating inlet pressure for a given port diameter is exceeded.

P203 P Flow Capacities in SCFH (Nm³/h) of 0.6 Specific Gravity Natural Gas

Outlet Pressure, Spring Part Number, and Accuracy	Inlet Pressure		NPT 1-1/2 Body Size					
			Orifice Size, Inches (mm)					
	PSIG	BAR	1/4 (6.4)	3/8 (9.5)	1/2 (13)	3/4 (19)	1 (25)	1-3/16 (30)
6 inches w.c. (15 mbar) 655-697-003 ±1 inch w.c. 2.5 mbar	0.4	0.028				1200 (32.2)	1500 (40.2)	1750 (46.9)
	0.5	0.034				1600 (42.9)	1900 (50.9)	2200 (59.0)
	1	0.07	400 (10.7)	900 (42.1)	1300 (34.8)	2300 (61.6)	2900 (77.7)	3300 (88.4)
	1.5	0.10	500 (13.4)	1150 (30.8)	1650 (44.2)	3000 (80.4)	3600 (96.5)	4300 (115)
	2	0.14	600 (16.1)	1400 (37.5)	2000 (53.6)	3500 (93.8)	4200 (113)	5500 (147)
	5	0.34	1000 (26.8)	2300 (61.6)	3500 (93.8)	5700 (153)	7300 (196)	7700 (206)
	13	0.90	1650 (44.2)	3700 (99.2)	6200 (166)	10,000 (268)	13,500 (362)	13,500 (362)
	25	1.7	2400 (64.3)	5200 (139)	9000 (241)	13,500 (362)	13,500 (362)	
	60	4.1	4400 (118)	9600 (257)	13,500 (362)	13,500 (362)		
	100	6.9	7000 (188)	13,500 (362)	13,500 (362)			
125	8.6	7000 (188)	13,500 (362)					
7 inches w.c. (17 mbar) 655-697-004 ± 1 inch w.c. 2 inches mbar	0.4	0.028				950 (25.5)	1350 (36.2)	1550 (41.5)
	0.5	0.034				1500 (40.2)	1700 (45.6)	1950 (52.3)
	1	0.07	400 (10.7)	800 (21.4)	1200 (52.2)	2000 (53.6)	2600 (85.8)	3000 (80.4)
	1.5	0.10	500 (13.4)	1050 (28.1)	1500 (40.2)	2550 (68.3)	3200 (85.8)	4100 (110)
	2	0.14	600 (16.1)	1300 (34.8)	1800 (48.2)	3000 (80.4)	3700 (99.2)	5000 (134)
	5	0.34	1000 (26.8)	2100 (56.3)	3100 (83.1)	5000 (134)	6500 (174)	7000 (188)
	13	0.90	1650 (44.2)	3300 (88.4)	5500 (147)	8600 (230)	12,000 (322)	13,500 (362)
	25	1.7	2400 (64.3)	5000 (134)	8000 (214)	13,500 (362)	13,500 (362)	
	60	4.1	4400 (118)	9400 (252)	13,500 (362)	13,500 (362)		
	100	6.9	7000 (188)	13,500 (362)	13,500 (362)			
125	8.6	7000 (188)	13,500 (362)					
11 inches w.c. (27 mbar) 655-697-005 ± 2 inches w.c. (5 mbar)	0.5	0.03				1450 (38.9)	1650 (44.2)	1850 (49.8)
	1	0.07	375 (10.1)	750 (20.1)	1100 (29.5)	1800 (48.2)	2500 (67.0)	2900 (77.7)
	1.5	0.10	475 (12.7)	1000 (26.8)	1450 (38.9)	2400 (64.3)	3100 (83.1)	3900 (105)
	2	0.14	550 (14.7)	1250 (33.5)	1700 (45.6)	3000 (80.4)	3600 (96.5)	4800 (129)
	5	0.34	950 (25.5)	2000 (53.6)	2900 (77.7)	4800 (129)	6500 (174)	6700 (180)
	13	0.90	1550 (41.5)	3100 (83.1)	5100 (137)	9000 (241)	11,000 (295)	13,500 (362)
	25	1.7	2260 (60.6)	4700 (126)	8000 (214)	13,500 (362)	13,500 (362)	
	60	4.1	4200 (113)	8900 (239)	13,500 (362)	13,500 (362)		
	100	6.9	6600 (177)	13,500 (362)	13,500 (362)			
	125	8.6	6600 (177)	13,500 (362)				
20 inches w.c. (50 mbar) 655-697-006 ± 3 inches w.c. (7 mbar)	1	0.07	300 (8.04)	500 (13.4)	950 (25.5)	1000 (26.8)	1300 (34.8)	2000 (53.6)
	2	0.14	500 (13.4)	950 (24.5)	1500 (40.2)	2000 (53.6)	2900 (77.7)	4000 (107)
	5	0.34	850 (22.8)	1700 (45.6)	2400 (64.3)	4000 (107)	5000 (134)	5300 (142)
	13	0.90	1350 (36.2)	2800 (75.0)	4400 (118)	6500 (174)	8700 (233)	13,500 (362)
	25	1.7	2000 (53.6)	4800 (129)	6600 (177)	10,000 (268)	13,500 (362)	
	60	4.1	3700 (99.2)	9000 (241)	12,700 (340)	13,500 (362)		
	100	6.9	6000 (161)	13,500 (362)	13,500 (362)			
	125	8.6	6000 (161)	13,500 (362)				
1 PSIG 0.069 BAR 655-697-007 ±0.2 PSIG 0.014 BAR	2.0	0.14	500 (13.4)	750 (20.1)	1100 (29.5)	1400 (37.5)	2400 (64.3)	3000 (80.4)
	6.0	0.41	1100 (29.5)	1800 (48.2)	2500 (67.0)	4000 (107)	5200 (139)	7000 (188)
	14	0.97	1500 (40.5)	3000 (80.4)	4500 (121)	7000 (188)	9000 (241)	13,500 (362)
	30	2.1	2300 (61.6)	4800 (129)	7000 (188)	11,000 (295)	13,500 (362)	
	60	4.1	4400 (118)	9200 (247)	10,500 (281)	13,500 (362)		
	100	6.9	7000 (188)	13,500 (362)	13,500 (362)			
	125	8.6	7000 (188)	13,500 (362)				
3 PSIG 0.069 BAR 655-697-008 ±0.6 PSIG 0.041 BAR	3.0	0.21	500 (13.4)	1000 (26.8)	1500 (40.2)	2000 (53.6)	3200 (85.8)	3600 (96.5)
	7.0	0.48	1000 (26.8)	2200 (59.0)	3400 (91.1)	5700 (152)	7000 (188)	8800 (236)
	14	0.97	1500 (40.2)	3000 (80.4)	5700 (153)	10,000 (268)	11,000 (295)	13,500 (362)
	30	2.1	2400 (63.3)	5000 (134)	7500 (201)	13,500 (362)	13,500 (362)	
	60	4.1	4300 (115)	9400 (252)	11,500 (308)	13,500 (362)		
	100	6.9	6800 (182)	11,400 (306)	13,500 (362)			
125	8.6	6800 (182)	11,400 (306)					

1. Limited due to boost

 - Shaded areas show where indicated droop would be exceeded regardless of capacity.

 - Shaded areas show where maximum operating inlet pressure for a given port diameter is exceeded.

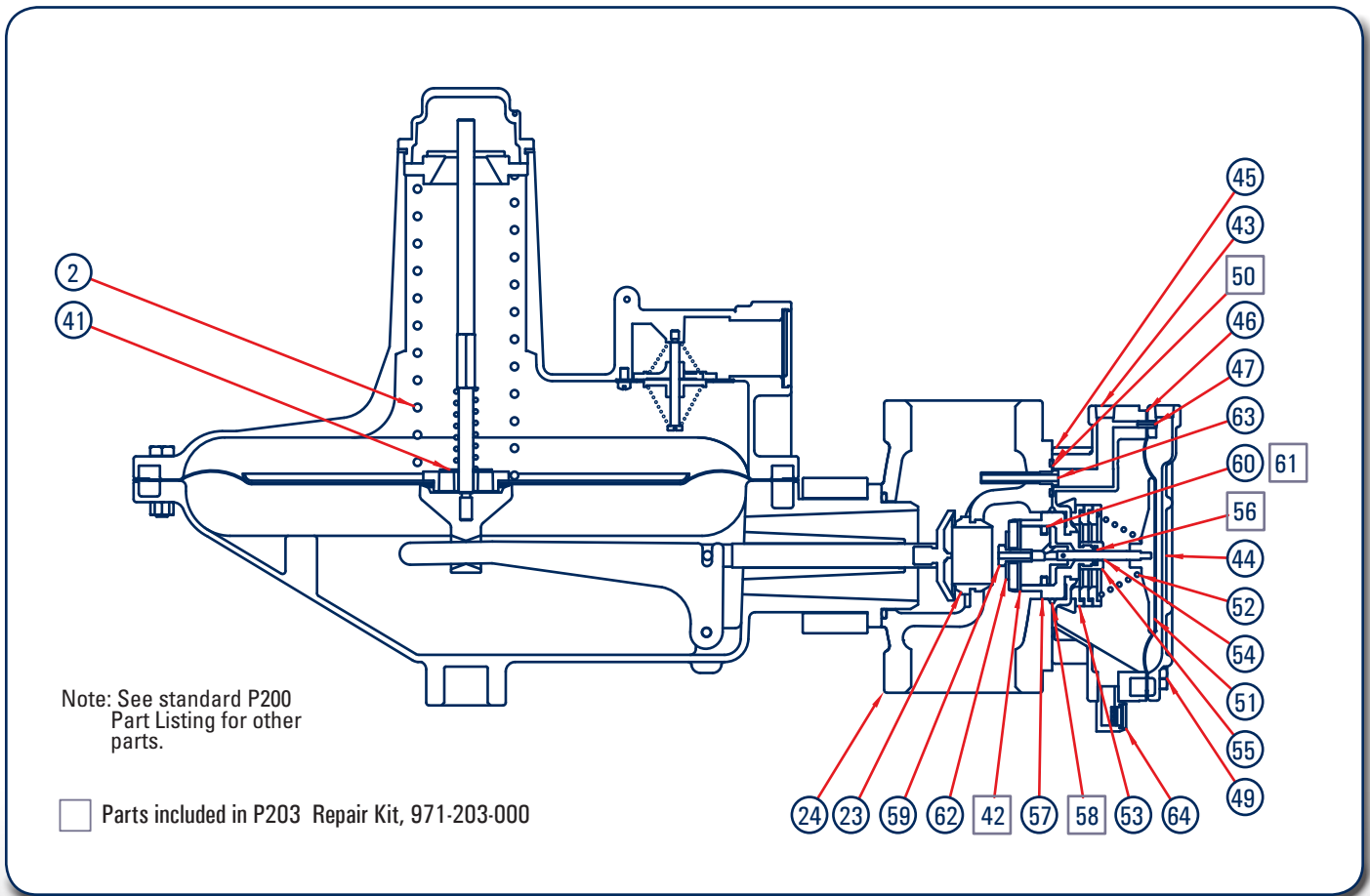

P203 Body Positions

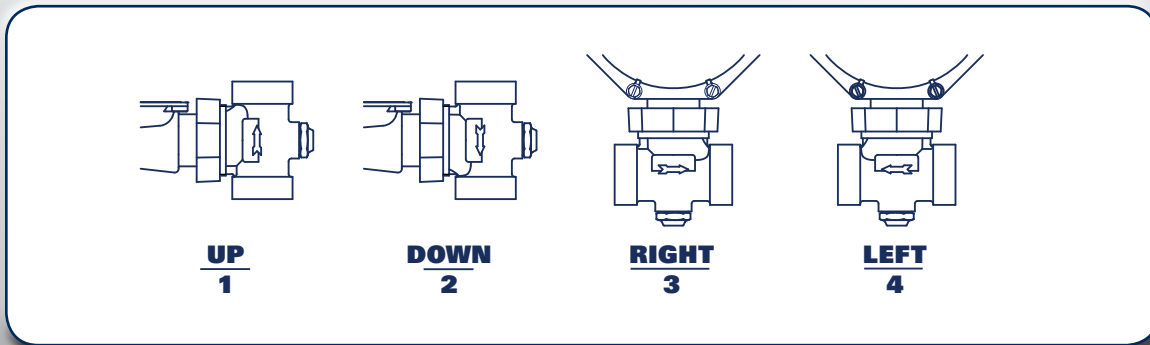

P203 Vent Positions

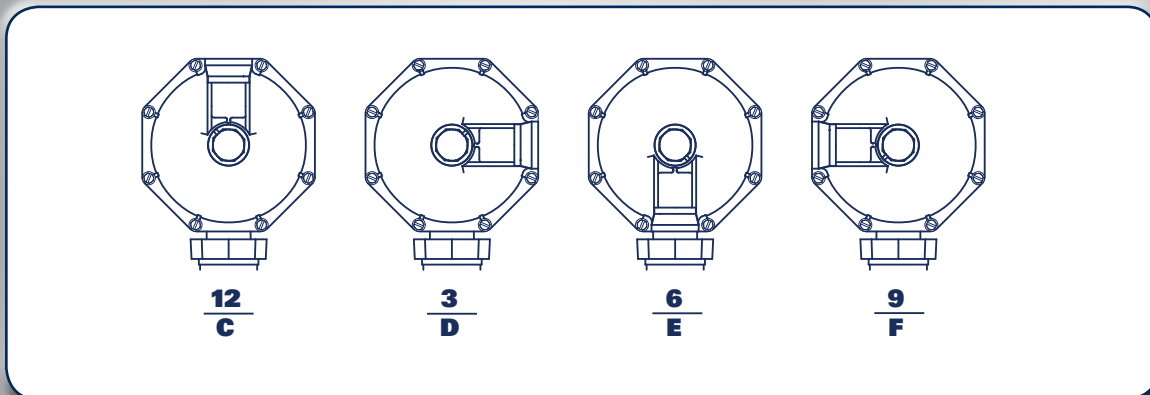

Item	Description	Qty.	Part Number
2	Range Spring - Normal (0)	1	See Table
	Brown, Plated Steel	1	655-697-002
	Red Plated Steel	1	655-697-003
	Black, Plated Steel	1	655-697-004
	Gray, Plated Steel	1	655-697-005
	Dark Green, Plated Steel	1	655-697-006
	Range Spring - High (H)		
	Dark Blue, Plated Steel	1	655-697-007
Orange, Plated Steel	1	655-697-008	
23	Orifices		
	1/4" Aluminum	1	688-061-000
	3/8" Aluminum	1	688-061-001
	1/2" Aluminum	1	688-061-002
	3/4" Aluminum	1	688-061-003
	1" Aluminum	1	688-061-004
24	Body		
	Iron 1.5" NPT	1	664-396-000
	Iron 1.5" x 2" NPT	1	664-396-001
	Iron 2" NPT	1	664-384-000
	Iron 2" , 125 FF	1	664-385-000
P203 Monitor Parts Only - See P200 for other Parts			
41	Relief Restriction	1	662-237-000
42	Disk Holder Assembly	1	822-044-000
43	Pipe Plug	2	639-000-054
44	Monitor Spring Case	1	604-264-000
45	Monitor Lower Case	1	629-237-000
46	Diaphragm	1	618-101-000
47	Roll Pin	1	635-074-000
48	Cap Screw	4	648-466-009
P203 Monitor Parts Only - See P200 for other Parts			
49	Cap Screw	8	648-466-000
50	O-ring	1	649-000-185
51	Diaphragm Plate	1	638-079-000
52	Monitor Springs		
	Green Spring (See Monitor Data Table)	1	655-746-000
	Red Spring (See Monitor Data Table)	1	655-746-001
	Blue Spring (See Monitor Data Table)	1	655-746-002
53	Silver Spring (See Monitor Data Table)	1	655-746-003
	Lower Spring Seat (See Monitor Data Table)	0-3	650-178-000
54	Piston Assembly	1	809-237-000
55	O-ring Retainer	1	643-206-000
56	Piston Assembly O-ring	1	649-000-001
57	Piston Guide	1	626-112-000
58	Piston Guide O-ring	1	649-309-003
59	Disk Holder Screw	1	648-545-000
60	Piston Ring Expander	1	644-062-000
61	Piston Ring	1	644-063-000
62	Washer	1	662-236-002
63	Pilot Tube	1	660-082-000
64	Vent Assembly	1	836-004-001
65	Sealing Screw (P203P only)	1	645-544-000
66	Stabilizer Gasket (P203S only)	1	624-088-000
67	Stabilizer Frame (P203S only)	1	704-008-000
68	Stabilizer Snap Ring (P203S only)	1	693-028-000

Item	Description	Qty.	Part Number
69	Stabilizer Neck (P203S only)	1	608-084-000

